

TBD4SS-5

Last updated June 2019

*Bellissimo*TM
BY TECHNICA

600mm Stainless steel freestanding dishwasher

Product Features

- 600mm Freestanding electronic dishwasher
- 12 Place settings
- 6 Washing Programs
- Push button function controls / blue indicator lights
- Delayed start (3, 6, 9 and 12 hours)
- Concealed Heating Element
- Height adjustable upper basket
- Foldable bottom plate racks
- Anti flood protection
- Noise level: 49dB
- 4.5 Star water rating
- 3 Star energy rating
- Connection: 10amp



Quiet

This dishwasher is quiet whilst in operation, so whether used during the day, or at night, conversations or sleeping children won't be interrupted.

Safety

This dishwasher has an anti flood system which cuts off the water supply if an overflow is detected, so you can be assured that your kitchen will remain protected from flood damage.

Programs

Our dishwashers are available with a range of programs, so your sure to find one that will work in with your lifestyle.

Environmentally friendly

Using 12 litres of water per wash, this dishwasher is water efficient.

Design

This dishwasher has been designed to compliment all of the cooking appliances in the Bellissimo range.

TBD4SS-5

Last updated June 2019

BellissimoTM
BY **TECHNIKA**

600mm Stainless steel freestanding dishwasher

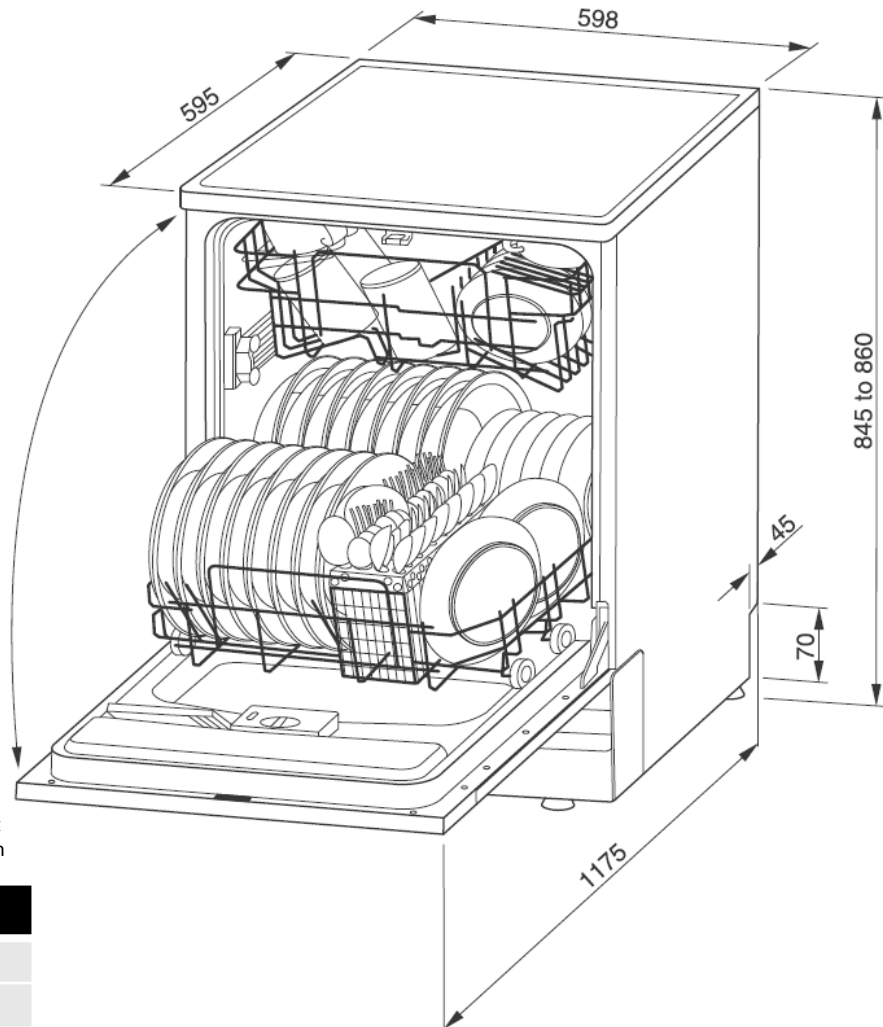
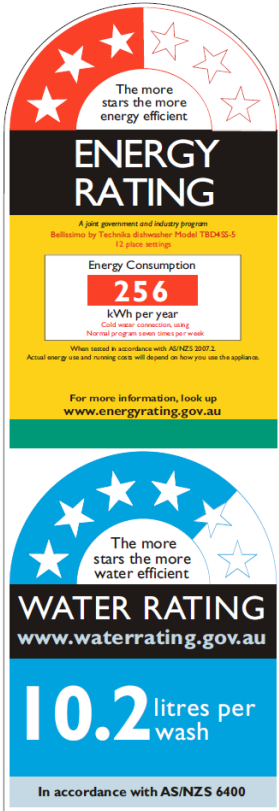

These dimensions are a guide only, please refer to product manual for up to date dimensions and product information

Dimensions	Width	Height	Depth
Cut-out (mm)	600	860*	600
Product (mm)	598	845*	595

* This dimension may vary due to adjustable legs

READ THE INSTRUCTION BOOKLET BEFORE INSTALLING AND USING THE APPLIANCE.

The manufacturer will not be responsible for any damage to property or to persons caused by incorrect installation or improper use of the appliance. The manufacturer is not responsible for any inaccuracies, due to printing or transcription errors, contained in this handout. In addition, the appearance of the figures reported is also purely indicative.

The manufacturer reserves the right to make changes to its products when considered necessary and useful, without affecting the essential safety and operating characteristics.

Technika constantly seeks ways to improve the specifications and designs of their products.

Whilst every effort is made to produce up to date literature, this document should not be regarded as an infallible guide.

Actual product only should be used to derive cut out sizes.

All Technika Appliances must be installed by a qualified person/s with adherence to the relevant electrical, plumbing and AGA codes, with compliance being issued as required by state or national legislation.

Additionally all Technika Upright cookers must have chains installed correctly in adherence to the relevant AGA, and plumbing codes by the Licenced installer.

For maximum effectiveness and efficiency all rangehoods should be installed with the use of ductwork, by a licenced installer with adherence to the relevant state and national building codes and regulations.

All Technika appliances are for Domestic use only, and must be installed by a licence installer into Domestic Applications only, without exception and to the required Authorities guidelines. Any installation outside of this will VOID warranty. Alfresco areas are not a Domestic application.