

TECHNIKA

PROFESSIONAL SERIES

USER GUIDE
**54CM FREESTANDING ELECTRIC
COOKER**
TFS54FC-SES

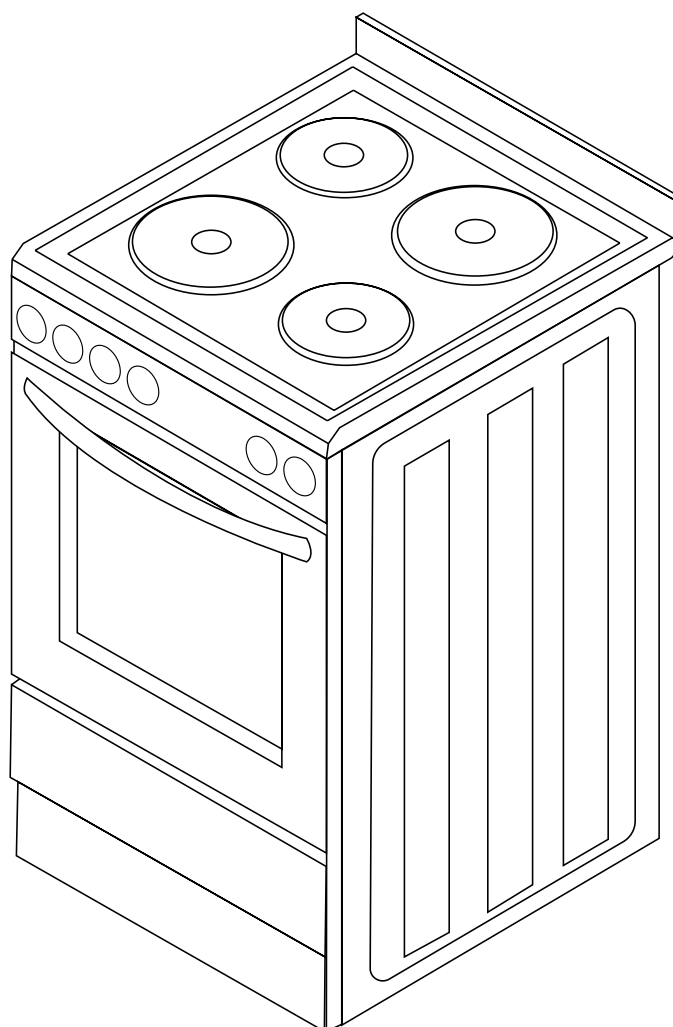

CONTENTS TABLE

Conditions of use.....	Pg 3
Safety precautions	Pg 4
Other important safety information.....	Pg 4
Warnings for use of oven and appliance hob.....	Pg 5
Product description	Pg 6
First time use of the appliance.....	Pg 7
Using the oven	Pg 8
Oven shelf location	Pg 9
Oven cooking guide	Pg 9
Understanding baking problems	Pg 10
Using the hotplates of your cooker	Pg 12
Cleaning the cooker	Pg 13
Information about the cooling fan	Pg 15
Replacing the oven light	Pg 15
Solving problems	Pg 16
Installing cooker - power connections	Pg 17
Installing your new cooker	Pg 18
Ambry installation	Pg 20
Technical specifications.....	Pg 20
Warranty	Pg 21

We recommend that you read the instructions in this manual carefully before use for the best performance and to extend the life of your appliance, as it will provide you with all the instructions you require to ensure its safe installation, use and maintenance. Always keep this manual close to hand since you may need to refer to it in the future. Thank you.

Condition of use:

This appliance is intended to be used for domestic use, not commercial use.

- This appliance is not intended for use by persons (including children) with reduced physical, sensory or mental capabilities, or lack of experience and knowledge, unless they have been given supervision or instruction concerning use of the appliance by a person responsible for their safety.
- Warning – ensure that no downward pressure is applied to the oven door when open. In particular, do not allow a child to climb on to open oven door
- Warning - accessible parts can become hot during use, especially the oven door. To avoid burns, young children must be kept away.
- Young children should be supervised to ensure they do not play with this appliance.
- During use this appliance becomes hot.
- Care should be taken to avoid touching hot external and internal surfaces when in use. Use oven gloves.
- Install cooker, shelving and fittings in accordance with this manual.
- Ensure all specified vents, openings and airspaces are not blocked.
- The appliance is not intended to be operated by means of external timer or separated remote-control system.
- CAUTION: The cooking process has to be supervised. A short term cooking process has to be supervised continuously.
- To ensure your safety all electric appliances should only be installed or service by qualified staff.
- If the supply cord when fitted, is damaged, it must be replaced a service agent or similarly qualified person in order to avoid a hazard.
- Do not spray aerosols in the vicinity of this appliance while it is in operation.
- Do not store flammable materials in the appliance or near this appliance.
- Do not modify this appliance.
- Appliance must be installed according to current laws and regulations by qualified tradesmen/Installers

The Manufacturers, Importers/Distributors and Retailers shall not be liable to any legal liability, personal injury and property damage due to incorrect operation or incorrect Installation.

Other important Safety information



This appliance must not be used as a space heater.



Do not obstruct the ventilation slots on front or back of appliance.



Do not remove any labels or use abrasive/ corrosive cleaners on.



According to the electrical safety regulations the appliance equipment must be properly earthed.



Do not use corrosive cleaners e.g. oven cleaners that contain caustic soda.

WARNINGS FOR USE OF OVEN AND APPLIANCE HOB

Oven Warnings

- Do not push down or apply any weight on open oven door.
- Do not line oven with foil or place anything on the bottom of the oven while baking to avoid permanent damage, as trapped heat will crack or craze the enamel floor of the oven cavity liner.
- Use of olive oil and other poly-unsaturated oils (vegetable oils) when roasting uncovered food causes deposits inside the oven which are very difficult to remove.

Hotplate and Burner Warnings

- Do not allow pots to boil dry, as damage to hotplate may result.
- Do not operate hotplates or burners without a pot, fry pan etc.
- Do not allow cookware to overhang hob onto adjacent bench tops, this will cause scorching to the bench top surface.
- Stainless steel sealing ring around the hotplate will discolour due to heat.
- Danger of fire: Do not store items on the cooking surface.
- WARNING: Unattended cooking on a hob with fat or oil can be dangerous and may result in a fire.
- If the hob surface or element is cracked, switch off the appliance to avoid the possibility of electric shock.

Disposal of packaging

- Please recycle the cardboard and also any polystyrene packaging where possible.

Installation, Cleaning and Servicing

- An authorised person must install this appliance.
- Before using the appliance, ensure that all packing materials are removed from the appliance.
- In order to avoid any potential hazard, the Installation Instructions must be followed.
- In order to avoid accidental tipping of the appliance (for example, by a child climbing onto the open oven door), the anti tilt plate must be installed.
- The cooker must not be placed on a base or plinth.
- The appliance must not be installed behind a decorative door in order to avoid overheating.
- Where the appliance is installed next to cabinets, the cabinet material must be capable of withstanding 85°C.
- Only authorised personnel should carry out servicing.
- Always ensure the appliance is switched off before cleaning.
- Do not use caustic soda- based cleaners.
- Do not use steam cleaners, as this may cause moisture build up.
- Always clean the appliance immediately after any food spillage.
- Appliances requiring connection to 220-240V and must be earthed.
- Means for disconnection must be incorporated in the fixed wiring in accordance with the wiring rules.

Description of Electric Cooker

1. Cooktop hob area
2. Hotplate Burner (4 of)
3. Control Panel
4. Chrome oven shelf (1 supplied)
5. Baking tray with grill insert (1 supplied)
6. Oven Door
7. Oven Inner Door Glass
8. Splashback (1 supplied)
9. Integrated Grill element
10. Fan forced oven element
11. Fan & element cover
12. Front panel
13. Anti-tilt bracket
14. Anti slip feet

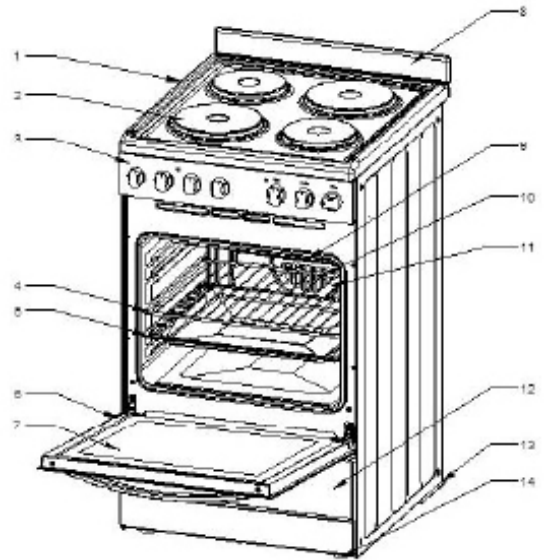

Controls

Front Control Panels

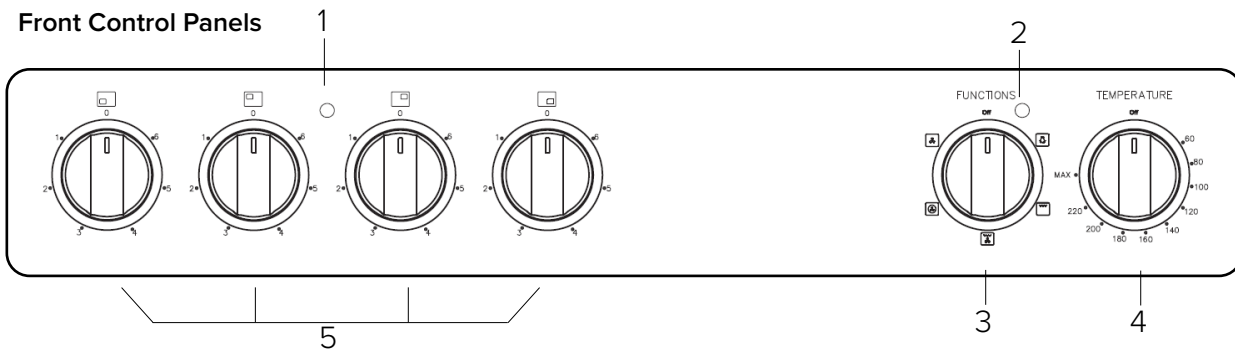

1. Hotplate Indicator Light (where fitted)
 - Comes on when a hotplate is turned on.
2. Oven Indicator Light
 - Light is on when oven element is heating up oven or cycling on.
3. Oven Function Control Knob
 - Sets oven function
4. Oven Temperature Control Knob
 - Sets temperature for baking.
5. Hotplate Control Knob
 - Adjusts temperature of hotplate.

FIRST TIME USE OF THE APPLIANCE

Fitting Oven Shelves

- Ensure shelf orientation is correct (refer picture).
- Slide into oven at an angle until raised back of shelf is past the stop on side runners.
- Lower front of shelf and push in until stop is reached.

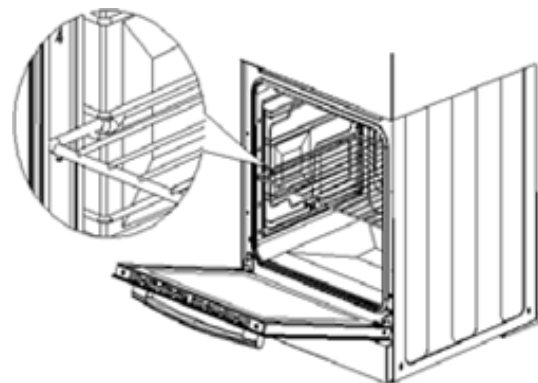

NOTE: The top ledge is not a shelf position

Preparing your appliance for the first time

- Wipe out the oven interior prior to operation with warm soapy water and polish dry with a soft clean cloth.
- New appliances can have an odour during first operation. It is recommended to 'run in' your oven before you cook for the first time. Run the oven at 180°C for 2-4 hours and ensure that the room is well ventilated.
- Please install oven furniture as outlined in the "Fitting Oven Accessories and Cleaning" section.
- If your appliance is fitted with solid hotplates, turn heat setting to high for 3 minutes to fully harden the coating. When cooled, apply a thin coating of cooking oil to seal the surface.

Using the oven

Oven Safety Warnings

- Always follow the instructions for putting the shelves and side racks into the oven, to avoid accidents.
- Do not line the oven with foil, it will damage the enamel.
- Do not place cookware or anything else on the bottom of conventional oven model as trapped heat will damage the oven
- Do not touch the hot surfaces or heating elements inside the oven.
- Do not use the oven door as a shelf.
- Do not push down on the open oven door.
- Do not place shelves on top of upper most shelf runner as there are no stops for shelf withdrawal.

Set Oven Functions

Description of oven functions



Light

The oven light is on. No heating elements are on.



Grill

The top central heating element comes on. Suitable for grilling food or browning food. Do not use lowest shelf position.



Fan Assisted Grill

The upper heating element and the fan come on. Suitable for grilling food without turning over and using two shelves. Do not use lowest shelf position



Fan Forced

The rear circular heating element and the fan come on to make heat distribution more even throughout the oven. This mode is ideal for general purpose cooking on 3 shelves at the same time.



Defrost

Only the fan operates. It is located on the back of the oven, making the air circulate at room temperature around the food. This is recommended for the defrosting of all types of food. By using the fan, the defrosting time is approximately halved .

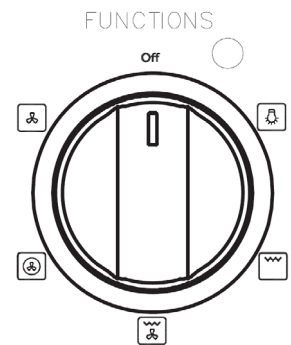

Set Cooking Temperatures

- Select cooking temperature by turning the knob clockwise to the required temperature, between 60c to MAX .
- Oven indicator light will come on when the oven is heating up.
- When it turns off it means that it reached the required temperature.
- The indicator light will cycle 'on & off' regularly during use which is normal.
- It means that oven temperature is being constantly maintained at the selected level.

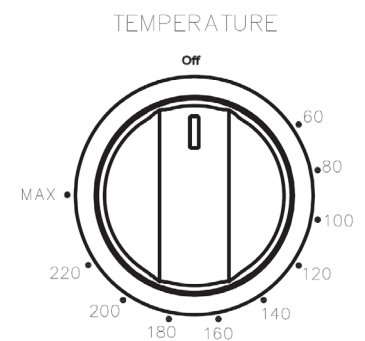

OVEN SHELF LOCATION

(5 shelf positions side racks)

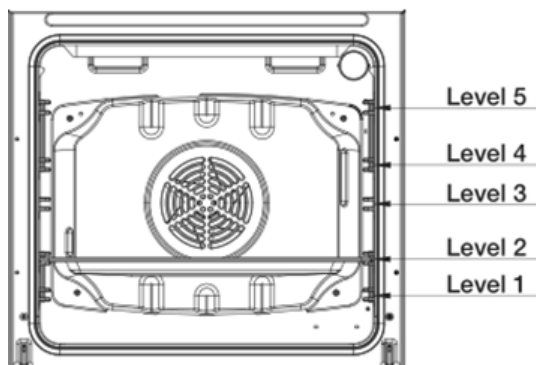

Oven cooking guide

The following is intended as a guide only. It is often required to set oven 10-20 degrees above or below this guide to get the result you want. Also adjustments are needed for the cooking time to suit personal desired results. Also you should follow the recipe guide when setting temperature and times. For best results when baking, preheat your oven for 15-20 minutes.

Food	Conventional Oven		Fan forced oven		Time in minutes
	Temperature	Oven shelf position	Temperature	Oven shelf position	
Plain or fruitscones	220	2 (3)	210	Any	10-15
Rolled biscuits	170 (180)	2	150 (170)	Any	10-15
Spooned biscuits	190	2	180	Any	12-15
Short bread biscuits	160	1 (2)	150	Any	30-35
Hard individual meringues	110	2	100	Any	90
Soft individual meringues	180	2	165	Any	15-20
Pavlova	110 (120)	1	100	Any	75
Patty cakes	190	2	180	Any	15-20
Sponge	180	2	170	Any	20-30
Plain butter cake	180	2	170	Any	25-40
Rich fruit cake	140 (150)	2	130	Any	180
Short crust cornish pastry	180-200	2	160 (180)	Any	40-45 (10-35)
Short crust custard tart	180-220	1 (3)	170 - 200	Any	20-30 (10/25)
Cream puffs	210	2	200	Any	25-30
Yeast bread	210	1	200	Any	25-30
Pizza	200	2	220	Any	15-25

Shelf position is counted from the bottom shelf position up. Bottom shelf position is 1.

Meat/Poultry/Fish		Recommended temperature (°C)	Minutes per kilogram
Beef	Rare	200	35-40
	Medium	200	45-50
	Well done	200	55-60
Lamb	Medium	200	40
	Well done		60
Veal		180	60
Pork		200	60
Chicken		180-200	45-60
Duck		180-200	60-70
Turkey		180	40-45 (less than 10kg)
			35-40 (more than 10kg)
Fish		180	20

UNDERSTANDING BAKING PROBLEMS

Problem	Causes	Remedy
Uneven cooking	Incorrect shelf position	Select shelf that puts food in center of oven
	Oven tray too large	Remove oven tray. Use smaller trays or dishes
	Trays not in center	Put trays in center
	Oven fan causing uneven browning or small cakes to lean over	Rotate food during cooking, or use Conventional Mode (i.e. no fan)
Baked products too brown on top	Oven not preheated	Preheat the oven
	Baking tins too large (diameter) for recipe	Use correct size tins
	Fan-forced mode with oven temperature too high	Check recipe. Reduce oven temperature by 10 – 20 or more
	Cooking time too long	Next time, shorten cooking time
	Baking tins not evenly spaced	Stagger baking tins at least 3cm between tins and the oven walls
	Items to be cooked are not evenly sized or spaced on trays	Make into same size and shape and spread evenly over trays
Baked products too brown on bottom	Baking tins too large (diameter)	Use correct size tins
	Baking tins are dark metal or glass	Change to shiny, light tins or lower the temperature by 10-20°C
	Food too low in oven	Cook one shelf higher
	Oven door opened too frequently during baking	Don't open the oven door until at least half the cooking time has passed
	Baking temperature too high	Lower the temperature
	Oven tray blocking heat (below thermostat)	Use higher shelf position for oven tray

Problem	Causes	Remedy
Cakes have a cracked thick crust	Baking temperature too high	Lower the temperature
	Food too low in oven	Cook one shelf higher
	Cake batter over mixed	Mix just long enough to combine the ingredients
	Baking tin too deep	Check size of tin and use recommended size
	Baking tins dark	Change to shiny light tins
Baked products are pale at and undercooked	Baking temperature too low	Raise the temperature
	Food too low in oven	Cook one shelf higher
	Baking time too short	Increase cooking time
	Incorrect baking tin size	Use correct size tin
Cakes fallen in center	Baking temperature too low	Raise the temperature
	Baking time too short	Increase cooking time
	Proportions of ingredients incorrect for recipe	Check recipe
	Opening door too early during baking	Do not open door until the last quarter of cooking time
Roast meat and potatoes not browning in fan oven	Poor hot air circulation	Elevate food onto a rack to a low air circulation
	Oven temperature is too low	Increase temperature to 200 - 220
	Not long enough in oven	Continue cooking for another 15+ minutes

NOTE: Condensation on oven door is normal, especially when kitchen is cold. Also spacing and size of food on trays and the number of baking dishes in the oven can affect air circulation.

Using the hotplates of your cooker

Hotplates safety warnings

- Do not use pots and pans which are unsteady, as these could overbalance.
- Do not use mats, heat diffusers or wok stands. These will cause a temperature build-up which can damage the cook top.
- Do not let cooking pots overhang sides or front of hob get too close to the hotplate control knobs.

Choosing cooking pots and pans

Look at this diagram below which shows you which utensils to use on the hotplates and which utensils should not be used.

- Always use pots and pans with flat bottoms. Uneven or thin bottoms will waste energy and cook slowly.
- Always use pots and pans which are slightly larger than the hotplate. Small pans waste energy.
- Always put dry pots and pans on the hotplates.
- Do not use pots and pans which are too large. Pots which overhang the hotplate more than 50mm can damage the hob



USING THE HOTPLATES OF YOUR COOKER

Check the hotplates on your cooker against the diagrams below before you use your cooker for the first time

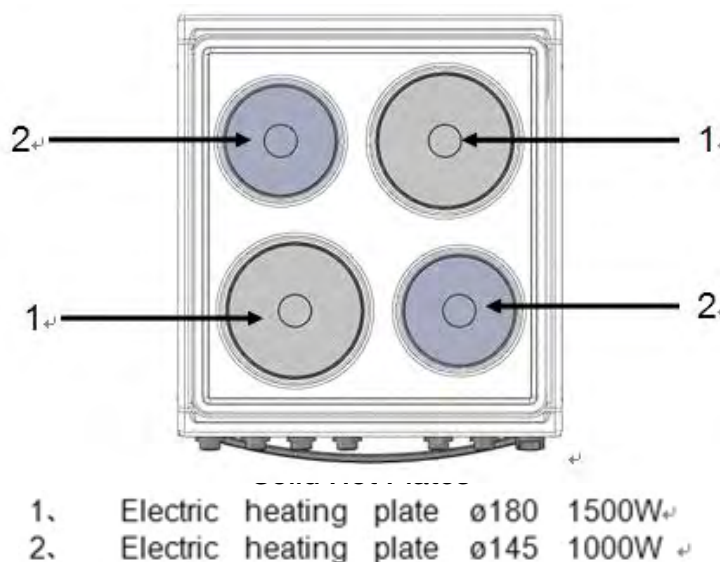

Solid hotplates

- The strong solid-cast hotplates give wide contact for fast, efficient cooking.
- The hotplates are sealed all around which means that spilt liquids do not go under the hotplates.

NOTE: The stainless steel ring will tarnish with use.

Before first use

- The top surface of the hotplates are sealed with a heat resistant coating. Before using for the first time the hotplates should be heated for a short period without a pan to harden the protective coating.
- Turn the heat setting to high for approx 3 minutes to fully harden the coating.
- When the hotplates have cooled apply a thin coating of cooking oil to the hotplate to seal and protect the surface.
- After switching off, this light will continue to glow until the temperature of the hotplate drops below 60°C

CLEANING THE COOKER

Safety warnings about cleaning

- Always make sure that the cooker is turned off before cleaning.
- Always clean cooker immediately after use.
- Do not use steam cleaners. These may cause moisture build-up.
- Do not use caustic- based cleaners. These will damage aluminums parts, and remove enamel gloss.

Cleaning the enamel

- Keep enamel clean by wiping it with a soft cloth dipped in warm soapy water.
- Rub difficult stains with a nylon scourer or creamed powder cleanser.
- Do not use abrasive cleaners, dry powder cleaners, steel wool or wax polishes.
- If you use an oven cleaner, then follow the instructions on the product carefully.

Cleaning the control panel

- Make sure control knobs are in off position.
- Clean the control panel by wiping it with a soft cloth dipped in warm soapy water and squeezed dry.

Cleaning the electric cook top

DO NOT PUT ELEMENT IN WATER!



Solid hotplates

- For normal cleaning use a moist cloth.
- For very dirty hotplates use any commercial cleanser (hotplate cleaner).
- After cleaning, remove any cleanser remaining and dry the hotplate completely running the element for a short period.
- For prolonged life of the hotplate we recommend Hillmark “Shine On” hotplate protector, or similar to prevent rust or corrosion. It is recommended this be done weekly.
- Permanent heat discolouration of the trim ring is normal

NOTE: Do not use abrasive sponges or scourers, oven sprays or stain removers on solid hotplates. These may damage, scratch or stain the hot plate. Any pitting, staining or scratching will not be covered by warranty.

Cleaning the Oven

- Open the door fully.
- Remove oven shelves and side racks.
- Clean with hot soapy water.

Cleaning the oven door / How to remove the oven door

For a more thorough clean, you can remove and disassemble the oven door.

Proceed as follows:

- Oven door structures 1 remove and assemble procedure:
- Open the door to the full extent (fig.1);
- Open the lever A completely on the left and right hinges (fig.2);
- Hold the door as shown in (fig.3)
- Gently close the door (fig.3) until left and right hinge levers A are hooked to part B of the door (fig.4).
- Withdraw the hinge hooks from their location following arrow C (fig.4).
- Rest the door on a soft surface;
- To replace the door, repeat the above steps in reverse order.

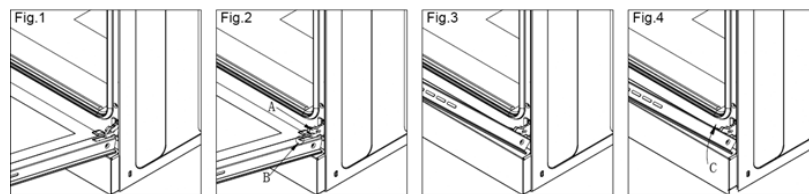

Removing the Inner Pane of Glass

- Oven door: Remove the seal G by unscrew the 2 screws (fig.1)
- Gently pull out the inner pane of glass (fig.2)
- Clean the glass with an appropriate cleaner. Dry thoroughly, and place on a soft surface.
- Now you can also clean the inside of the outer glass.

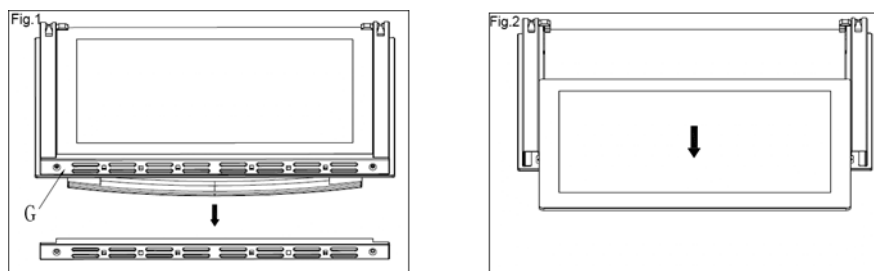

Cleaning the door glass

- Clean the glass door using non-abrasive products or sponges and dry it with a soft cloth.
- Do not use the oven without the inner door glass fitted.
- Do not use harsh abrasive cleaners or sharp metal scrapers to clean the oven door glass since they can scratch the surface, which may result in shattering of the glass.

INFORMATION ABOUT THE COOLING FAN

NOTE: Your cooker is fitted with a cooling fan that will run after the oven has been turned off.

To reduce the time of the cooling fan running time it is suggested to open door ajar to assist in cooling down of oven.

REPLACING THE OVEN LIGHT

Ensure that the appliance is switched off before replacing the lamp to avoid the possibility of electric shock.

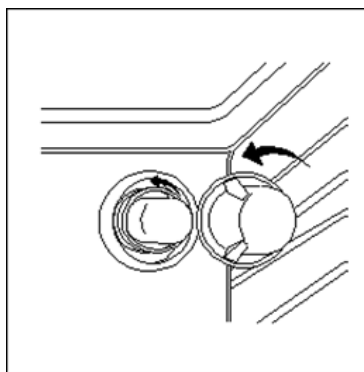

- Disconnect the oven from the power supply at the fuse-box by means of the switch used to connect the appliance to the electrical mains.
- Remove the glass cover of the lamp-holder by rotating anti-clockwise
- Remove the lamp and replace with a lamp resistant to high temperatures (300°) with the following characteristics:
 - » Voltage: 220-240V
 - » Wattage: 25W
 - » Type: E 14
- Replace the glass cover. Reconnect the appliance to the mains power supply.

SOLVING PROBLEMS

Problem	Causes	Remedy
Elements won't work	Circuit breaker tripped	Check circuit breaker
	Household fuse blown	Replace household fuse
Oven or grill not working	120 min Timer now in Manual position	Refer to 120 min timer instructions
	Power not turned on	Switch on electricity
	Control is incorrectly set	Reset controls
	Circuit breaker tripped	Check circuit breaker
Oven light not working	Power not turned on	Switch on electricity
	Household fuse blown	Check fuses
	Circuit breaker tripped	Check circuit breaker
	Lamp blown or loose in socket	Replace or tighten globe
Oven not hot enough	Heat escaping through incorrectly sealed door	Check shelves or dishes are not preventing door closing properly. Check that door is fitted properly after door removal for cleaning
	Door seal is worn or has moved	Replace seal or re set it
Unit smoking when first used	Protective oils being removed	This is normal
Odour on first use of oven	Manufacturing oils on elements	This is normal
120minute timer buzzer not audible	Timer not wound sufficiently	Allow 2-4 hours for odour to dissipate (open all windows)
Oven shelf tight	Oven shelf not inserted correctly, may be upside down or back to front	Turn timer knob past 15 minute mark. Then turn to the required number of minutes.
Clock display off	Household fuse blown or power supply is off	Remove shelf and insert as per diagram
		Check fuses, power supply

Note: Only Euromaid Authorised service agents should carry out servicing otherwise warranty may be void.

INSTALLING COOKER - POWER CONNECTIONS

Fitting a power supply cable

Connecting appropriate power supply terminal board/ connector block:

- Using a screwdriver, prize open tabs of the Terminal board cover.
- Remove the wire clamp screw.
- Fasten the wires beneath the corresponding screw heads, using brass 'bridge' for single phase supply.
- Fasten cable clamp and close the cover of the terminal board.
- The ac power supply should be 220-240V / 50-60Hz. Cooker is rated at 6560-7810W connected load. For electric cookers, the minimum 32A circuit breaker. When connecting to multiphase supply, remove the relevant bridge pieces between ACTIVE connections

NOTE: To be carried out by a qualified electrician / installer.

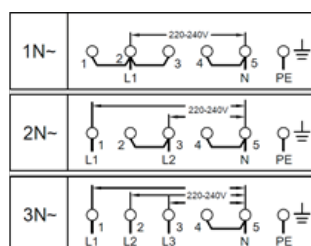
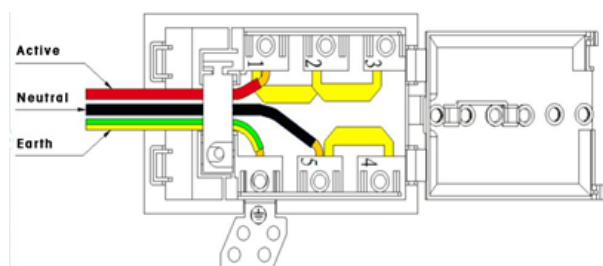

WARNING: CONNECTING THE POWER CORD MUST BE IN ACCORDANCE WITH THE INSTRUCTIONS LISTED IN THE TABLE BELOW

Wire cross-sectional area (mm ²) Connection mode	L2	L2	L3	N	E
1N ~	Min 6	-	-	Min 6	Min 6
2N ~	Min 2.5	Min 2.5	-	Min 6	Min 6
3N ~	Min 2.5	Min 2.5	Min 2.5	Min 6	Min 6

Connecting the supply cable to the mains

Install an approved circuit breaker with a minimum contact opening of 3 mm, between the appliance and the mains fuse box. The circuit breaker should be sized according to the load and should comply with current regulations (the earth wire should not be interrupted by the circuit breaker).

The supply cable should be positioned so that it does not reach a temperature of more than 50° with respect to the room temperature, anywhere along its length. Before switching fuse ON in meter-box check:

- Earth continuity. The electrical safety of this appliance can only be guaranteed if the cooker is correctly installed and earthed, in compliance with regulations on electrical installations.
- The electrical capacity of the system and sockets will support the maximum power of the appliance, as indicated on the data plate
- Go to section "Installing your new cooker"

INSTALLING YOUR NEW COOKER

Safety warnings about installation

- The cooker must be installed and serviced only by an authorised person.
- A certificate of compliance must be supplied by Installer and is to be kept by the customer.
- The packing materials must be removed before you install the cooker.
- You must follow the installation instructions in this booklet.
- The surrounding kitchen cabinets must be able to withstand 85°C. We will not accept responsibility for damage caused by installation in to kitchen cabinets which cannot withstand 85°C.
- The vents; openings and air spaces must not be blocked.
- The anti-tilt plate must be installed to avoid accidental tipping.
- The stabilizing bolt must be installed to avoid accidental moving.
- You must not pull the cooker by the door handles.
- Electricity isolation switch for electric models 32A plug, is to be installed in an accessible position near the cooker (but not behind cooker).
- If the supply cord or cable is damaged, it must be replaced by an approved service agent or a similarly qualified person in order to avoid a hazard.

Unpacking and installation instructions for installer

Unpacking

- Please check the product and make sure that there is no damage.
- Read the relevant Installation Sections of this Manual. Ensure all is understood.
- Confirm that product is compatible with available electrical connections.
- Ensure proposed installation position does not conflict with Installation Sections.
- Check the attachment packing in good condition, complete accessories.
- Use screw driver to remove two fixed Anti-tilt plate screws and plate.

Locating the cooker

Study the diagrams below to be sure of the dimensions required to locate the cooker safely. Make sure that the top of the cooker is at least 10mm higher than the level of the bench tops. The appliance has been designed to fit in a 540mm wide gap in kitchen cabinets. The cooker may also be installed at the end of a line of benches or with a free space on either side.

NOTE: To ensure cooker stability, the anti-tilt plate must be installed on the cooker.

The installation the splash back

- Upon unpacking cooker, using a philips head screwdriver to remove splashback from rear of cooker.
- Position splash back into tabs at rear of cooker and push downwards gently until properly in position.
- Screw in splashback from behind to secure in place.

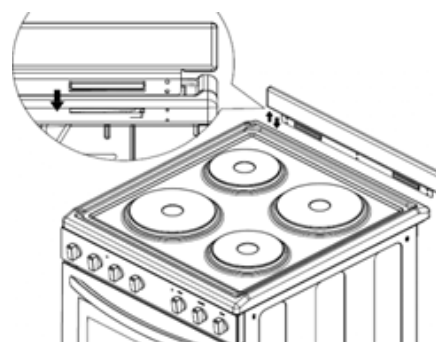

(Refer to diagram relating to minimum clearances required for correct installation)

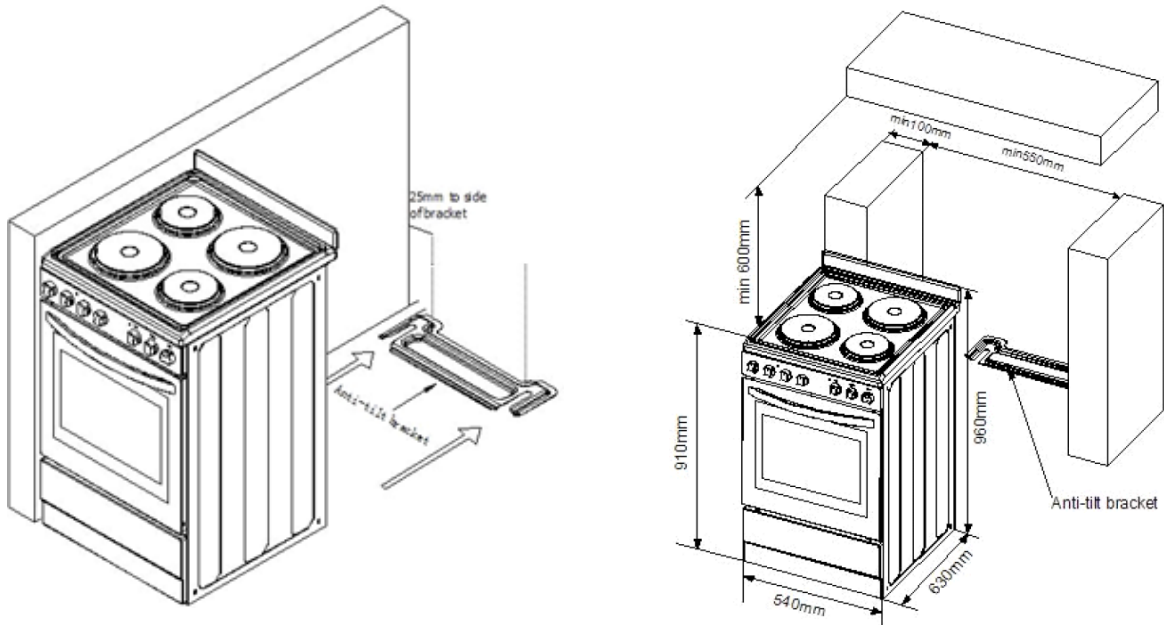

- Determine position of cooker and anti-tilt plate.
- Securely fix the anti-tilt plate to the floor with appropriate fasteners.
- Slide the cooker into the anti-tilt plate to double check. And then slide out the cooker.
- Connect electricity supply but do not turn on until installation is completed.
- Slide the cooker back into the anti-tilt plate so that rear cover rests against the rear wall. Then check the height and level of the cooker. If required, pull the cooker back out and adjust the leveling feet as required.

SAFETY CHAIN

The appliance must be secured against the possibility of tipping forward by using the supplied safety chains attached to the rear of your oven. Fasten the stability hook provided by inserting a wall plug into the kitchen wall and then connect the safety chain to the hook via the locking mechanism.

1. Safety chain (supplied and mounted to oven)
2. Stability hook
3. Chain attachment for the rear of the cooker
4. Rear of the cooker
5. Kitchen wall

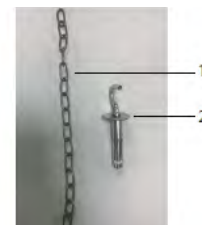
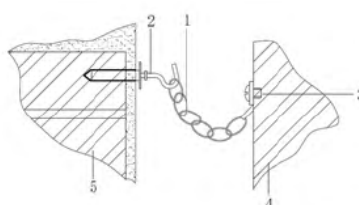

AMBRY INSTALLATION

Only a qualified person in compliance with the instructions provided must install the appliance.

Manufacturer declines all responsibility for improper installation, which may harm persons and damage property.

Important

The power supply to the appliance must be turned off before any adjustments or maintenance work is to be carried out on the cooker. Air vents at the rear of the cooker should not be fully covered otherwise ventilation will be restricted and cause possible damage to the cooker.

TECHNICAL SPECIFICATIONS

Model	TFS54FC-SEW
Oven capacity (L)	83
Voltage (v)	220-240
Frequency (Hz)	50-60
Circuit breaker (A)	32amp
Power	6560-7810W
Product dimension (mm)	540*630*910
Package size (mm)	590*712*960

MANUFACTURER GUARANTEE

This warranty is provided in Australia by Glen Dimplex Australia Pty Limited ABN 69 118 275 460 **(Phone number 1300 556 816)** and in New Zealand by Glen Dimplex New Zealand Limited NZBN 9429000069823 **(Phone number 09 274 8265)** in respect of the **Technika Professional** product.

1. Technika Professional Express Warranty

Subject to the exclusions below, we warrant that the product will not have any electrical or mechanical breakdowns within:

- a) In the case of **Technika Professional** products used for personal, domestic or household purposes, a period of 2 years from the date the product is purchased as a brand-new product from a retailer located in Australia / New Zealand.
- b) In the case of **Technika Professional** products used for purposes other than personal, domestic or household purposes (including business or commercial use), a period of 90 days from the date the product is purchased as a brand-new product from a retailer located in Australia / New Zealand. **Technika Professional** products are designed and intended for domestic use only; and
- c) All warranty repairs must be carried out by Glen Dimplex or their nominated service agent

Note: warranty periods detailed above may vary in line with agreements with select retail and builder partners and may differ between Australia and New Zealand.

The benefits conferred by this express warranty are in addition to the Consumer Guarantees referred to in section 3 and any other statutory rights you may have under the Australian / New Zealand Consumer Law and/or other applicable laws.

2. Warranty exclusions

This express warranty does not apply where:

- a) The product has been installed, used or operated otherwise than in accordance with the product manual or other similar documentation provided to you with the product;

MANUFACTURER GUARANTEE

- b) The product requires repairs due to damage resulting from accident, misuse, incorrect installation, insect or vermin infestation, improper liquid spillage, cleaning or maintenance, unauthorised modification, use on an incorrect voltage, power surges and dips, voltage supply problems, tampering or unauthorised repairs by any persons, use of defective or incompatible accessories or exposure to abnormally corrosive conditions, events independent of human control which occurred after the goods left the control of Glen Dimplex;
- c) The repair relates to the replacement of consumable parts such as fuses and bulbs or any other parts of the product which require routine replacement;
- d) You are unable to provide us with reasonable proof of purchase for the product;
- e) the breakdown occurs after the expiry of the express warranty period set out in section 1 or
- f) the product was not purchased in Australia / New Zealand as a brand-new product.

3. Consumer guarantees

Our goods come with guarantees that cannot be excluded under the Australian / New Zealand Consumer Law. You are entitled to a replacement or refund for a major failure and for compensation for any other reasonably foreseeable loss or damage. You are also entitled to have the goods repaired or replaced if the goods fail to be of acceptable quality and the failure does not amount to a major failure.

4. How to make a claim

You may make a claim under this warranty through our website, contacting our customer care line or via email. Contact details for Glen Dimplex Australia and New Zealand can be found at the end of this document

To make a valid claim under this warranty, you must:

- a) Lodge the claim with us as soon as possible and no later than 14 days after you first become aware of the breakdown;
- b) Provide us with the product serial number;
- c) Provide us with reasonable proof of purchase for the product. This can take the form of a store receipt, new home handover form or other payment receipt documentation; and
- d) If required by us, provide us (or any person nominated by us) with access to the premises at which the product is located at times nominated by us (so that we can inspect the product).

MANUFACTURER GUARANTEE

5. Warranty claims

If you make a valid claim under this warranty and none of the exclusions set out in section 2 apply, we will, at our election, either repair the product or replace the product with a product of identical specification (or where the product is superseded or no longer in stock, with a product of as close a specification as possible).

Goods presented for repair may be replaced by refurbished goods of the same type rather than being repaired. Refurbished parts may be used to repair the goods.

Products are designed and supplied for normal domestic use. We will not be liable to you under this warranty for business loss or damage of any kind whatsoever.

Glen Dimplex Australia Pty Ltd

www.glendimplex.com.au

Australia

Ph: 1300 556 816

customer.care.ha@glendimplex.com.au

Glen Dimplex New Zealand Ltd

www.glendimplex.co.nz

New Zealand

Ph: 09 274 8265

nztechserv@glendimplex.co.nz

MANUFACTURER GUARANTEE

READ THE INSTRUCTION BOOKLET BEFORE INSTALLING AND USING THE APPLIANCE.

The manufacturer will not be responsible for any damage to property or to persons caused by incorrect installation or improper use of the appliance.

The manufacturer is not responsible for any inaccuracies, due to printing or transcription errors, contained in this manual. In addition, the appearance of the figures reported is also purely indicative.

The manufacturer reserves the right to make changes to its products when considered necessary and useful, without affecting the essential safety and operating characteristics.

Glen Dimplex constantly seeks ways to improve the specifications and designs of their products.

Whilst every effort is made to produce up to date literature, this document should not be regarded as an infallible guide. Actual product only should be used to derive cut out sizes.

All appliances must be installed by a qualified person/s with adherence to the relevant electrical, plumbing and building codes, with compliance being issued as required by state or national legislation.

Additionally, all upright cookers must have the anti-tilt device installed correctly in adherence to the relevant standards by a licenced installer. For maximum effectiveness and efficiency all rangehoods should be installed with the use of ductwork, by a licenced installer with adherence to the relevant state and national building codes and regulations.

All Glen Dimplex appliances are for Domestic use only, and must be installed by a licence installer into Domestic Applications only, without exception and to the required Authorities guidelines. Any installation outside of this will VOID warranty. Alfresco areas are not a Domestic application.



Distributed by:

Glen Dimplex Australia Pty Ltd

For full terms and conditions, or to register your product warranty, please visit our website:

www.glendimplex.com.au

Glen Dimplex New Zealand Ltd

www.glendimplex.co.nz

For service advice, please contact the Customer Care Centre by phone or email below.

Australia

Ph: 1300 556 816

customer.care.ha@glendimplex.com.au

New Zealand

Ph: 09 274 8265

nztechserv@glendimplex.co.nz