

**TECHNIKA<sup>®</sup>**  
COOKING WITH PASSION

**HOME COLLECTION**

**DESIGNED IN  
AUSTRALIA FOR EVERY  
AUSTRALIAN HOME**

---





Technika has helped Australian families make lasting memories for over 25 years. Every appliance we make is designed right here in Australia to perfectly meet the needs of the Australian homeowner. With a stunning aesthetic inspired by the great Italian designers and technology from the world's most innovative manufacturers, Technika appliances are the gold standard. Surround yourself with the sophistication and style of our most popular range and join Australia's leading builders in choosing Technika for your home.



# INDEX

---

## **BUILT-IN OVENS**

4 - 8

## **UPRIGHT COOKERS**

9 - 13

## **COOKTOPS**

14 - 19

## **RANGEHOODS**

20 - 28

## **MICROWAVES**

29 - 30

## **DISHWASHERS**

31 - 33

## **LAUNDRY**

34 - 35

## **INSTALLATION DRAWINGS**

36 - 48

## **WARRANTY**

49

# COOKING FUNCTIONS

---



## FULL GRILL

Cooks using heat from both the grill and top elements, suitable for grilling a range of food like meat & fish.



## FAN GRILL

Uses both the fan & the grill element to circulate heat around the food, ideal for browning meat.



## CONVENTIONAL

A traditional method of cooking using heat from both the top & bottom elements, great for cooking a variety of food on a single shelf.



## FAN ASSIST

Cooks using heat from the top & bottom elements, plus the fan to distribute heat evenly around the oven for faster cooking, suitable for baking pastries.



## FAN FORCED

Cooks using both the fan and the element around the fan to distribute heat around the oven, resulting in faster, more even cooking. Great for using multiple shelves at the same time.



## TOP HEAT

Uses heat from the top element & is ideal for browning food as the heat isn't as intense as the grill.



## BASE HEAT

Cooks using the bottom element for slow, gentle cooking or to keep food warm before serving.



## BASE HEAT + FAN

Cooks using the bottom element plus the fan to distribute heat evenly around the oven; for slow, gentle cooking or to keep food warm before serving.



## MULTI-COOKING

Intensive cooking using heat from all three elements plus the fan to distribute heat around the oven to cook faster and more evenly.



## PIZZA

Combining the fan forced & base heat functions to rapidly heat the oven. Ideal for cooking pizza or other dishes requiring a crispy base.



## DEFROST

Using the fan to circulate air around the food without any heat to defrost frozen foods quickly and safely.



## LIGHT

The light illuminates the oven cavity allowing you to check on the progress of your cooking with ease.



## PYROCLEAN

A self-cleaning function that uses a high temperature to reduce food residue to ash.



## HALF GRILL

Directs radiant heat from the powerful upper element onto the food.



## AIRFRY

Offering a convenient, counter-saving option that promotes healthier eating eliminating the need for extra oil and extra appliances in the kitchen.



## ECO

Excellent for those cooking in smaller proportions with its energy saving capabilities.



## INTENSIVE BAKE

Combining the fan forced & top heat functions to evenly distribute heat around the oven, whilst also directing radiant heat from the top element for extra crispy results.

Please Note: Not all functions are relevant to each model.

A close-up photograph of a roasted turkey on a wooden cutting board. The turkey is golden brown and garnished with fresh green herbs. The background is a dark, textured surface.

# BUILT-IN OVEN

## FEATURES AND BENEFITS

### TELESCOPIC SHELVES

Strong enough to hold even the heaviest cookware, our telescopic shelves effortlessly glide in and out for easy loading and checking of your meal's progress.

### TRIPLE GLAZED DOOR

Three layers of glass keeps heat in so your food cooks quickly and efficiently. Triple glazing also limits the amount of heat that can escape, so the door remains cooler to touch.

### LARGE COOKING CAPACITY

Our large capacity ovens allow you to cater for even the biggest of dinner parties. Completely adjustable shelving gives you the flexibility to accommodate all types of cookware with ease.

### EASY TO CLEAN

Removable doors, side racks, and easy clean interiors allow food particles to be easily wiped away. For best results, wipe away any spills with a damp cloth once the oven has cooled down.



## TO605TBX 60cm 5 Function Built-In Oven

### Key Features

Stainless steel + black glass finish	Closed door grilling
85 litre capacity	Removable triple glazed door
5 functions	Soft-close hinges
Knob controls	2x wire shelves
Programmable LED touch timer	1x baking tray
5 shelf positions	1x grill insert
Oven light	10A electrical connection

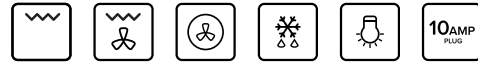

## TO610TBX 60cm 10 Function Built-In Oven

### Key Features

Dark stainless steel + black glass finish	Closed door grilling
85 litre capacity	1x full extension telescopic rail
10 functions	Premium braided oven seal
Knob controls	Removable triple glazed door
Programmable LED touch timer	2x wire shelves
5 shelf positions	1x baking tray
Oven light	1x grill insert
Soft-close hinges	15A electrical connection

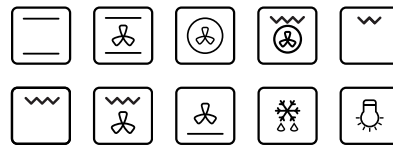

## TO615AFBX 60cm 15 Function Built-In Oven

### Key Features

Dark stainless steel + black glass finish	1x full extension telescopic rail
85 litre capacity	Premium braided oven seal
15 functions including Air Fry + Steam Clean	Programmable timer + minute minder
Full touch interface with smart digital display	Removable triple glazed door
Programmable LED touch timer	Child lock
5 shelf positions	2x wire shelves
Oven light	1x baking tray
Soft-close hinges	1x grill insert
Closed door grilling	1x Air fry basket
	15A electrical connection







## TGP0611ABK 60cm 11 Function Built-In Oven

### Key Features

- Dark stainless steel + black glass finish
- 85 litre capacity
- 11 functions including Pyro Clean + Air Fry
- Central electronic dial + touch control
- Programmable LED touch timer
- 5 shelf positions
- Soft-close hinges
- 1x full extension telescopic rail
- Premium braided oven seal
- Removable triple glazed door
- 2x wire shelves
- 1x baking tray
- 1x grill insert
- 1x Air fry basket
- Durable easy-clean blue enamel interior
- 15A electrical connection

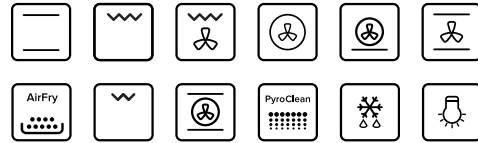

## TSO605TX-R 60cm 5 Function Side Opening Built-In Oven

### Key Features

- Dark stainless steel + black glass finish
- 67 litre capacity
- 5 functions
- Knob control
- Programmable LED touch timer
- 5 shelf positions
- Oven light
- Closed door grilling
- Side opening door (right-hand hinge)
- 1x full extension telescopic rail
- Removable triple glazed door
- 2x wire shelves
- 1x baking tray
- 1x grill insert
- 10A electrical connection



## TSO605TX-L 60cm 5 Function Side Opening Built-In Oven

### Key Features

- Dark stainless steel + black glass finish
- 67 litre capacity
- 5 functions
- Knob control
- Programmable LED touch timer
- 5 shelf positions
- Oven light
- Closed door grilling
- Side opening door (left-hand hinge)
- 1x full extension telescopic rail
- Removable triple glazed door
- 2x wire shelves
- 1x baking tray
- 1x grill insert
- 10A electrical connection





## TTDT910-6 90cm 10 Function Built-In Oven

### Key Features

- |  |                                   |
|--|-----------------------------------|
| Dark stainless steel<br>+ black glass finish       | Program memory                    |
| 110 litre capacity                                 | 1x full extension telescopic rail |
| 10 functions                                       | Removable triple glazed door      |
| Full touch interface<br>with smart digital display | Child lock                        |
| 4 shelf positions                                  | 2x wire shelves                   |
| Twin oven lights                                   | 1x baking tray                    |
| Closed door grilling                               | 1x grill insert                   |
|  | 15A electrical connection         |

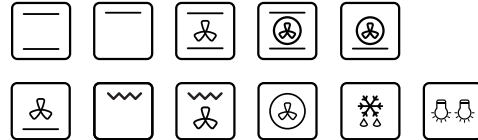

## T948SS-6 90cm 10 Function Built-In Oven

### Key Features

- |  |                                   |
|--|-----------------------------------|
| Stainless steel + black glass finish               | Program memory                    |
| 110 litre capacity                                 | 1x full extension telescopic rail |
| 10 functions                                       | Removable triple glazed door      |
| Full touch interface<br>with smart digital display | Child lock                        |
| 4 shelf positions                                  | 2x wire shelves                   |
| Twin oven lights                                   | 1x baking tray                    |
| Closed door grilling                               | 1x grill insert                   |
|  | 15A electrical connection         |





# UPRIGHT COOKER

## FEATURES AND BENEFITS

### TWIN CIRCULATING FANS

This feature allows a greater volume of heat and air to be distributed around the oven, allowing faster heat up times and more even heat distribution. This ultimately means better cooking results - especially when baking.

### LARGE VIEWING WINDOW

Easily check the progress of your meal without having to open the door and let hot air escape.

### EASY TO CLEAN

Removable doors, side racks and easy clean interiors allow food particles to be easily wiped away.

### TRIPLE GLAZED DOOR

Three layers of glass keeps heat in so your food cooks quickly and efficiently. Triple glazing also limits the amount of heat that can escape, so the door remains cooler to touch. This is a handy safety feature for little fingers.

### STORAGE COMPARTMENT

Store extra cookware in the storage compartment to free up space in other areas of your kitchen.



## T640TE8

### 60cm 8 Function Dual Fuel Upright Cooker

#### Key Features

- |                                     |                                   |
|-------------------------------------|-----------------------------------|
| Stainless steel finish              | Easy clean interior               |
| 56 litre capacity                   | Removable triple glazed door      |
| 8 functions                         | Removable side racks              |
| 6 button programmable digital timer | Large viewing window              |
| 4 gas burners including wok         | Storage compartment               |
| Removable cast iron trivets         | Automatic safety cut off          |
| Wok adaptor                         | Cavity cooling system             |
| Flame failure device                | Automatic ignition                |
| Splashback                          | Removable inner glass door panels |
| Single oven fan                     | Available with LPG conversion     |
| Close door grilling                 | 15A electrical connection         |
| Single oven light                   |                                   |

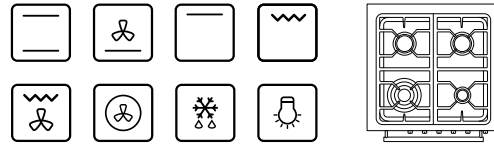

## GHE09TDSS-4

### 90cm 8 Function Dual Fuel Upright Cooker

#### Key Features

- |                                     |                                   |
|-------------------------------------|-----------------------------------|
| Stainless steel finish              | Single oven light                 |
| 56 litre capacity                   | Easy clean interior               |
| 8 functions                         | Removable triple glazed door      |
| 6 button programmable digital timer | Removable side racks              |
| 5 gas burners                       | Large viewing window              |
| Centre located wok burner           | Automatic safety cut off          |
| Removable cast iron trivets         | Cavity cooling system             |
| Wok adaptor                         | Automatic ignition                |
| Flame failure device                | Removable inner glass door panels |
| Splashback                          | Available with LPG conversion     |
| Twin oven fans                      | 15A electrical connection         |
| Close door grilling                 |                                   |





## TU950TME8 90cm 8 Function Dual Fuel Upright Cooker

### Key Features

- |                                     |                                   |
|-------------------------------------|-----------------------------------|
| Stainless steel finish              | Twin oven lights                  |
| 105 litre capacity                  | Easy clean interior               |
| 8 functions                         | Removable triple glazed door      |
| 6 button programmable digital clock | Removable side racks              |
| 5 gas burners                       | Large viewing window              |
| Centre located wok burner           | Storage compartment               |
| Removable cast iron trivets         | Automatic safety cut off          |
| Wok adaptor                         | Cavity cooling system             |
| Flame failure device                | Automatic ignition                |
| Splashback                          | Removable inner glass door panels |
| Twin oven fans                      | Available with LPG conversion     |
| Close door grilling                 | 15A electrical connection         |

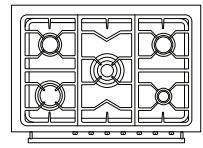
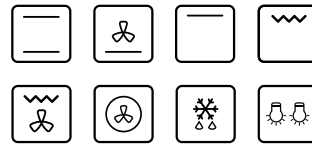

## TU950TLE8 90cm 8 Function Dual Fuel Upright Cooker

### Key Features

- |                                     |                                   |
|-------------------------------------|-----------------------------------|
| Stainless steel finish              | Twin oven lights                  |
| 105 litre capacity                  | Easy clean interior               |
| 8 functions                         | Removable triple glazed door      |
| 6 button programmable digital clock | Removable side racks              |
| 5 gas burners                       | Large viewing window              |
| Left hand side located wok burner   | Storage compartment               |
| Removable cast iron trivets         | Automatic safety cut off          |
| Wok adaptor                         | Cavity cooling system             |
| Flame failure device                | Automatic ignition                |
| Splashback                          | Removable inner glass door panels |
| Twin oven fans                      | Available with LPG conversion     |
| Close door grilling                 | 15A electrical connection         |

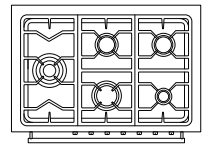
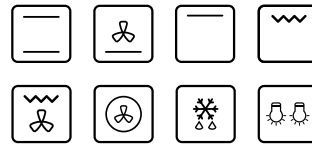



## TU950TME8BG

### 90cm 8 Function Dual Fuel Upright Cooker

#### Key Features

- |                                      |                                   |
|--------------------------------------|-----------------------------------|
| Stainless steel + black glass finish | Twin oven lights                  |
| 105 litre capacity                   | Easy clean interior               |
| 8 functions                          | Removable triple glazed door      |
| 6 button programmable digital clock  | Removable side racks              |
| 5 gas burners                        | Large viewing window              |
| Centre located wok burner            | Storage compartment               |
| Removable cast iron trivets          | Automatic safety cut off          |
| Wok adaptor                          | Cavity cooling system             |
| Flame failure device                 | Automatic ignition                |
| Splashback                           | Removable inner glass door panels |
| Twin oven fans                       | Available with LPG conversion     |
| Close door grilling                  | 15A electrical connection         |

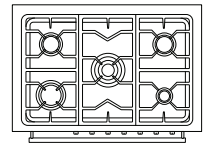
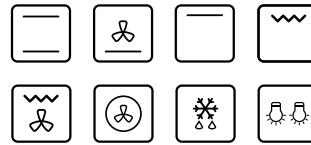

## TU950TLE8G

### 90cm 8 Function Dual Fuel Upright Cooker

#### Key Features

- |                                      |                                   |
|--------------------------------------|-----------------------------------|
| Stainless steel + black glass finish | Twin oven lights                  |
| 105 litre capacity                   | Easy clean interior               |
| 8 functions                          | Removable triple glazed door      |
| 6 button programmable digital clock  | Removable side racks              |
| 5 gas burners                        | Large viewing window              |
| Left hand side located wok burner    | Storage compartment               |
| Removable cast iron trivets          | Automatic safety cut off          |
| Wok adaptor                          | Cavity cooling system             |
| Flame failure device                 | Automatic ignition                |
| Splashback                           | Removable inner glass door panels |
| Twin oven fans                       | Available with LPG conversion     |
| Close door grilling                  | 15A electrical connection         |

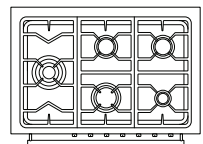
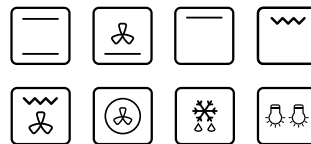



## TEG95TBK

### 90cm 8 Function Dual Fuel Upright Cooker

#### Key Features

- |                                      |                                   |
|--------------------------------------|-----------------------------------|
| Matte black + stainless steel finish | Removable triple glazed door      |
| 105 litre capacity                   | Removable side racks              |
| 8 functions                          | 1x full extension telescopic rail |
| 5 gas burners                        | Large viewing window              |
| 3 wok burners + wok ring             | Storage compartment               |
| Programmable LED touch timer         | Automatic safety cut off          |
| Removable cast iron trivets          | Cavity cooling system             |
| Flame failure device                 | Automatic ignition                |
| Splashback                           | Removable inner glass door panels |
| Twin oven fans                       | Available with LPG conversion     |
| Close door grilling                  | 15A electrical connection         |
| Twin oven lights                     |                                   |
| Easy clean interior                  |                                   |

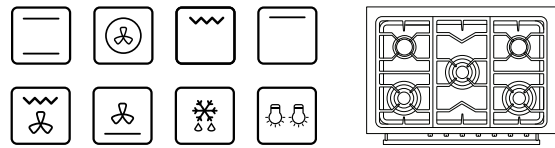

## CERHE09PSS-2

### 90cm 8 Function Electric Upright Cooker

#### Key Features

- |                                     |                               |
|-------------------------------------|-------------------------------|
| Stainless steel finish              | Easy clean interior           |
| 105 litre capacity                  | Removable triple glazed door  |
| 8 functions                         | Removable side racks          |
| 5 zone ceramic cooktop              | Large viewing window          |
| + 2 extendable cooking zones        | Storage compartment           |
| 6 button programmable digital clock | Automatic safety cut off      |
| Splashback                          | Cavity cooling system         |
| Twin oven fans                      | Available with LPG conversion |
| Close door grilling                 | 15A electrical connection     |
| Twin oven lights                    |                               |

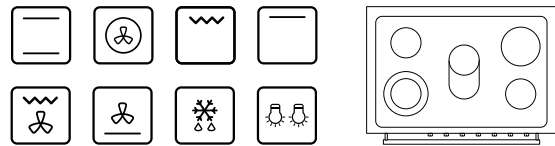



# COOKTOP

## FEATURES AND BENEFITS

### EFFICIENCY AND SPEED

Our Induction cooktops transfer heat directly to cookware using state of the art technology. This means that heat is instant, precise, and only heats your cookware - not surrounding areas, making it extremely energy efficient and safe.

### SAFETY

On our electric cooktops the child lock allows the control panel to be locked so programs can't be altered. On our gas cooktops the flame failure device shuts off the gas supply should the flame be extinguished for any reason.

### EASY TO CLEAN

A smooth finish, removable control knobs and trivets allow for easy cleaning. For best results wipe away any spills with a damp cloth from the surface once the cooktop has cooled down.

### SENSOR TOUCH CONTROLS

Simply press the sensor touch control until the desired heat level is achieved. From a low simmer to a high boiling point, any level of heat is easily obtained.

### EXTENDABLE ZONES

Extendable zones on selected ceramic cooktops join together to become one large zone, making them perfect for large pans. When joined together the individual zones maintain the same temperature so the same level of heat is obtained across the larger zone.

\* NB - Not all features on this page are on all models. Please refer to the product user manual for the features that apply to your model.





## H320SXFFPRO-2 30cm Gas Cooktop

### Key Features

---

Stainless steel finish  
2 gas burners  
Removable cast iron trivet  
Electronic ignition  
Front located removable control knobs

Flame failure device  
Available with LPG conversion  
10A electrical connection



## H640STXFFPRO-3 60cm Gas Cooktop

### Key Features

---

Stainless steel finish  
4 gas burners  
Left hand side triple ring wok burner  
Wok adaptor  
Heavy duty removable cast iron trivets

Electronic ignition  
Front located removable control knobs  
One piece hob  
Flame failure device  
Available with LPG conversion  
10A electrical connection



## TGC6GWFSS 60cm Gas Cooktop

### Key Features

---

Stainless steel finish  
4 gas burners  
Left hand side triple ring wok burner  
Wok adaptor  
Heavy duty removable cast iron trivets

Electronic ignition  
Front located removable control knobs  
One piece hob  
Flame failure device  
Available with LPG conversion  
10A electrical connection



## TGC6GWBGFS 60cm Gas Cooktop

### Key Features

---

Black glass + stainless steel finish  
4 gas burners  
Left hand side triple ring wok burner  
Wok adaptor  
Heavy duty removable cast iron trivets

Electronic ignition  
Front located removable control knobs  
One piece hob  
Flame failure device  
Available with LPG conversion  
10A electrical connection



## **TGC9GLWFSS** 90cm Gas Cooktop

### Key Features

---

Stainless steel finish  
5 gas burners  
Side located triple ring wok burner  
Wok adapter  
Heavy duty removable cast iron trivets  
Electronic ignition

Front located removable control knobs  
One piece hob  
Flame failure device  
Available with LPG conversion  
10A electrical connection



## **H950SLTXFPRO** 90cm Gas Cooktop

### Key Features

---

Stainless steel finish  
5 gas burners  
Side located triple ring wok burner  
Wok adapter  
Removable cast iron trivets  
Electronic ignition

Front located removable control knobs  
One piece hob  
Flame failure device  
Available with LPG conversion  
10A electrical connection



## **H950STXFPRO** 90cm Gas Cooktop

### Key Features

---

Stainless steel finish  
5 gas burners  
Centre located triple ring wok burner  
Wok adapter  
Removable cast iron trivets  
Electronic ignition

Front located removable control knobs  
One piece hob  
Flame failure device  
Available with LPG conversion  
10A electrical connection



## **TGC9GLWBGFS** 90cm Gas Cooktop

### Key Features

---

- |  |                                       |
|--|---------------------------------------|
| Black glass + stainless steel finish   | Front located removable control knobs |
| 5 gas burners                          | One piece hob                         |
| Side located triple ring wok burner    | Flame failure device                  |
| Wok adapter                            | Available with LPG conversion         |
| Heavy duty removable cast iron trivets | 10A electrical connection             |
| Electronic ignition                    |                                       |



## **H950STBGFPRO** 90cm Gas Cooktop

### Key Features

---

- |                                       |                                       |
|---------------------------------------|---------------------------------------|
| Black glass finish                    | Front located removable control knobs |
| 5 gas burners                         | One piece hob                         |
| Centre located triple ring wok burner | Flame failure device                  |
| Wok adapter                           | Available with LPG conversion         |
| Removable cast iron trivets           | 10A electrical connection             |
| Electronic ignition                   |                                       |

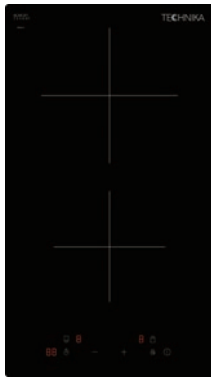

## 2RSS-5 30cm Ceramic Cooktop

### Key Features

---

Premium Schott-Ceran glass  
2 cooking zones  
9 power levels per zone  
Touch control  
99 minute timer

Child lock  
Automatic safety switch-off  
Residual heat indicators  
3000W total power  
12.5amp electrical connection

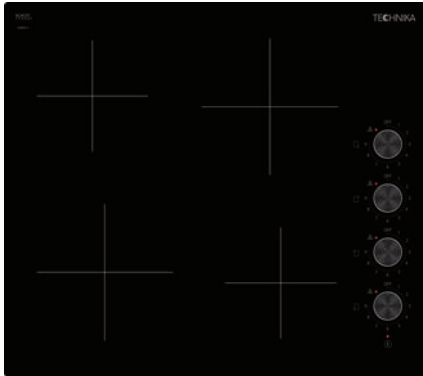

## CFM641-5 60cm Ceramic Cooktop

### Key Features

---

Premium Schott-Ceran glass  
4 cooking zones  
9 power levels per zone  
Black rotary control knobs  
Touch control on / off key

Automatic safety switch-off  
Residual heat indicators  
Frameless bevelled edges  
6000W total power  
25amp electrical connection

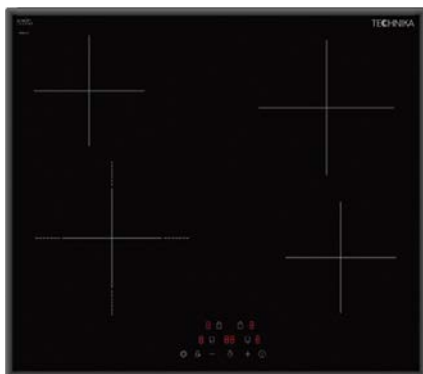

## CFE641-5 60cm Ceramic Cooktop

### Key Features

---

Premium Schott-Ceran glass  
4 cooking zones  
+ 1 extendable zone  
9 power levels per zone  
Touch control  
99 minute timer

Child lock  
Automatic safety switch-off  
Residual heat indicators  
Frameless bevelled edges  
6400W total power  
26amp electrical connection



## TGC6IND-5 60cm Induction Cooktop

### Key Features

---

Premium Schott-Ceran glass	Automatic cooking timer
4 cooking zones	Child lock
+ 1 smart flexi-zone	Pan sensors
9 power levels + boost per zone	Residual heat indicators
Slide touch control	On / off indicator
Left & right cooking segments with separate on / off & function controls	Frameless bevelled edges
	7200W total power
	30amp electrical connection



## 95HTSS-5 90cm Ceramic Cooktop

### Key Features

---

Premium Schott-Ceran glass	Automatic cooking timer
5 cooking zones	Child lock
+ 2 extendable zones	Residual heat indicators
9 power levels per zone	On / off indicator
Slide touch control	Frameless bevelled edges
Sensor touch on / off key	9000W total power
99 minute timer	37.5amp electrical connection
Keep warm + pause settings	



## TGC9IND-5 90cm Induction Cooktop

### Key Features

---

Premium Schott-Ceran glass	Automatic cooking timer
5 cooking zones including 2 smart flexi-zones + 1 extra large zones	Child lock
9 power levels + boost per zone	Pan sensors
Premium Schott-Ceran glass	Residual heat indicators
Slide touch control	On / off indicator
3 cooking segments with separate on / off and function controls	Frameless bevelled edges
	10800W total power
	45amp electrical connection



# RANGEHOOD

## FEATURES AND BENEFITS

### LED LAMPS

LED lamps are known for low energy consumption and long life, making them an efficient source of light.

### DESIGN & STYLE

With a comprehensive range of undermount, slideout and canopy rangehoods, you're sure to find the right product to complement any style of kitchen.

### SUPERIOR AIR EXTRACTION

With up to 1000m<sup>3</sup>/hr air extraction and up to 4 speeds you can control the level of air you need to remove different levels of odours.

### EASY TO CLEAN

Stainless steel & glass finishes throughout the series make cleaning your rangehood a breeze.



## **TSSUR52S\*** 52cm Single Speed Concealed Undermount Rangehood

### Key Features

---

Stainless steel finish  
700m<sup>3</sup>/hr airflow  
Single speed  
2x LED lamps

1x durable honeycomb filter  
Ducted operation  
10A electrical connection\*



## **TUR52S** 52cm Concealed Undermount Rangehood

### Key Features

---

Stainless steel finish  
Push button electronic control  
700m<sup>3</sup>/hr airflow  
3 speed

2x LED lamps  
1x durable honeycomb filter  
Ducted operation  
10A electrical connection



## **TGU52BK** 52cm Undermount Rangehood

### Key Features

---

Black glass finish  
Touch control  
1000m<sup>3</sup>/hr airflow  
3 speed

2x 2 watt LED strip lights  
1x aluminium mesh filter  
Ducted operation  
10A electrical connection

\*Model TSSUR52S is a concealed undermount rangehood with a single fixed speed and light. The rangehood contains no on / off switch and has a 10amp plug connection. When plugged in and the power point is switched on, the rangehood fan and light will come on automatically.



## **TUR70S** 70cm Concealed Undermount Rangehood

### Key Features

---

Stainless steel finish	2x LED lamps
Push button electronic control	1x durable honeycomb filter
700m <sup>3</sup> /hr airflow	Ducted operation
3 speed	10A electrical connection



## **TUR90S** 90cm Concealed Undermount Rangehood

### Key Features

---

Stainless steel finish	2x LED lamps
Push button electronic control	1x durable honeycomb filter
700m <sup>3</sup> /hr airflow	Ducted operation
3 speed	10A electrical connection



## **TGU90BK** 90cm Undermount Rangehood

### Key Features

---

Black glass finish	2x 2 watt LED strip lights
Touch control	1x aluminium mesh filter
1000m <sup>3</sup> /hr airflow	Ducted operation
3 speed	10A electrical connection





## **SL10160I-4** 60cm Slideout Rangehood

### Key Features

---

Stainless steel finish	1x 40 watt lamps
Switch control	2x aluminium filters
250m <sup>3</sup> /hr airflow	Ducted operation
2 speed	10A electrical connection



## **SL20260ISS-3** 60cm Slideout Rangehood

### Key Features

---

Stainless steel finish	2x 40 watt lamps
Switch control	2x aluminium filters
370m <sup>3</sup> /hr airflow	Ducted operation
2 speed	10A electrical connection
Twin motor	



## **SREC0160I-2** 60cm Recirculating Slideout Rangehood

### Key Features

---

Stainless steel finish	2x 40 watt lamps
Switch control	2x aluminium filters
250m <sup>3</sup> /hr airflow	Recirculated operation
2 speed	10A electrical connection



### **SL10190ISS-4** 90cm Slideout Rangehood

#### Key Features

---

- |                               |                           |
|-------------------------------|---------------------------|
| Stainless steel finish        | 1x 40 watt lamp           |
| Switch control                | 2x aluminium filters      |
| 250m <sup>3</sup> /hr airflow | Ducted operation          |
| 2 speed                       | 10A electrical connection |



### **SL10290ISS-3** 90cm Slideout Rangehood

#### Key Features

---

- |                               |                           |
|-------------------------------|---------------------------|
| Stainless steel finish        | 2x 40 watt lamps          |
| Switch control                | 2x aluminium filters      |
| 370m <sup>3</sup> /hr airflow | Ducted operation          |
| 2 speed                       | 10A electrical connection |
| Twin motor                    |                           |



### **SREC0190SS-2** 90cm Recirculating Slideout Rangehood

#### Key Features

---

- |                               |                           |
|-------------------------------|---------------------------|
| Stainless steel finish        | 2x 40 watt lamps          |
| Switch control                | 2x aluminium filters      |
| 250m <sup>3</sup> /hr airflow | Recirculated operation    |
| 2 speed                       | 10A electrical connection |



## **CHEM52C6S-5** 60cm Canopy Rangehood

### Key Features

---

Stainless steel finish	2x LED lamps
Electronic push button control	2x aluminium filters
760m <sup>3</sup> /hr airflow	Ducted operation
4 speed	10A electrical connection
Timer	



## **BG96A6-5** 60cm Curved Glass Canopy Rangehood

### Key Features

---

Stainless steel + glass finish	2x LED lamps
Electronic push button control	1x aluminium filters
760m <sup>3</sup> /hr airflow	Ducted operation
4 speed	10A electrical connection
Timer	



## **FHEE22A6S-5** 60cm Glass Deluxe Canopy Rangehood

### Key Features

---

Stainless steel + black glass finish	2x LED lamps
Touch & slide control	2x stainless steel baffle filters
1000m <sup>3</sup> /hr airflow	Ducted operation
4 speed	10A electrical connection
Timer	



## **CHEM52C9S-5** 90cm Canopy Rangehood

### Key Features

---

Stainless steel finish	2x LED lamps
Electronic push button control	3x aluminium filters
760m <sup>3</sup> /hr airflow	Ducted operation
4 speed	10A electrical connection
Timer	



## **CHEM52C9CL-5** 90cm Short Flue\* Canopy Rangehood

### Key Features

---

Stainless steel finish	2x LED lamps
Electronic push button control	3x aluminium filters
760m <sup>3</sup> /hr airflow	Ducted operation
4 speed	10A electrical connection
Timer	



## **CHEM52TLX** 90cm Deluxe Canopy Rangehood

### Key Features

---

Stainless steel finish	2x LED lamps
Touch & slide control	3x stainless steel baffle filters
1000m <sup>3</sup> /hr airflow	Ducted operation
4 speed	10A electrical connection
Timer	

\*For installations with bulkheads or limited ceiling height.



## **FHEE22A9S-5** 90cm Canopy Rangehood

### Key Features

---

Stainless steel finish	2x LED lamps
Touch & slide control	3x aluminium filters
1000m <sup>3</sup> /hr airflow	Ducted operation
4 speed	10A electrical connection
Timer	



## **FHEE26A9S-5** 90cm Glass Canopy Rangehood

### Key Features

---

Stainless steel + black glass finish	2x LED lamps
Touch & slide control	3x aluminium filters
1000m <sup>3</sup> /hr airflow	Ducted operation
4 speed	10A electrical connection
Timer	



## **FHEE229SC9S-5** 90cm Glass Deluxe Canopy Rangehood

### Key Features

---

Stainless steel + black glass finish	2x LED lamps
Touch & slide control	3x stainless steel baffle filters
1000m <sup>3</sup> /hr airflow	Ducted operation
4 speed	10A electrical connection
Timer	



## **FHEE91A9S-5**

### **90cm Curved Glass Deluxe Canopy Rangehood**

#### **Key Features**

---

Stainless steel + glass finish  
Touch & slide control  
1000m<sup>3</sup>/hr airflow  
4 speed  
Timer

2x LED lamps  
1x stainless steel baffle filters  
Ducted operation  
10A electrical connection



## **ICF9BLS\***

### **90cm Flat Island Canopy Rangehood**

#### **Key Features**

---

Stainless steel + black glass finish  
Touch control  
1000m<sup>3</sup>/hr airflow  
3 speed

4x 3 watt lamps  
3x stainless steel baffle filters  
Ducted operation  
10A electrical connection



## **TAR1200S**

### **120cm Alfresco BBQ Rangehood**

#### **Key Features**

---

High quality grade stainless steel finish  
Electronic push button control  
2000m<sup>3</sup>/hr airflow  
3 speed

Twin motors  
Timer  
4x LED lamps  
8x stainless steel baffle filters  
10A electrical connection



# MICROWAVES

## FEATURES AND BENEFITS

### **PREMIUM FEATURES**

With features ranging from quick start to auto cooking menus, there are options to suit all your needs for quickly heating your food to creating gourmet meals.

### **SEAMLESS INTEGRATION**

Installing flush into the cabinetry for a clean and seamless finish.



## **WD905-2** 28L Integrated Microwave

### Key Features

---

Stainless steel cavity & trim	Speed cooking
28 litre capacity	Multi-stage cooking function
8 auto cooking menus	30 second quick start
5 power levels	Defrost (by weight / time)
Digital control	95 minute kitchen timer
Push-in rotary control knob	Child safety lock
White LED display	900W total power



## **BD28MBK\*** 28L Integrated Microwave

### Key Features

---

Black acrylic with black glass door	Speed cooking
Stainless steel interior finish	Multi-stage cooking function
28 litre capacity	30 second quick start
8 auto cooking menus	Defrost (by weight / time)
5 power levels	95 minute kitchen timer
Digital control	Child safety lock
Push-in rotary control knob	900W total power
White LED display	

\*Branded Belling not Technika.





# DISHWASHER FEATURES AND BENEFITS

## LARGE CAPACITY

With up to 14 place settings and a height adjustable upper basket, our dishwashers can easily accommodate large plates or tall wine glasses.

## CONVENIENCE

The LED display tells you everything you need to know about your cycle so you'll always be fully informed. On certain models you can also delay the cycle for up to 24 hours, which means your dishwasher can be ready to unload when you are home.

## WIDE CHOICE OF PROGRAMS

With up to 8 wash programs and a variety of additional functions including extra dry, delay start and half load, there is a cycle to suit every need.

## INSTALLATION

With models featuring Freestanding, Fully-Integrated or Bench-top installation, there is an option to suit every kitchen.



## TEBTDWS-5 55cm Compact Dishwasher

### Key Features

---

Stainless steel finish	Overflow protection
6 place setting + cutlery basket	Rinse aid indicator
6 washing programs	2.5 star energy rating
2 / 4 / 6 / 8 hour delay start	3.5 star WELS rating, (per 7.4 litre wash)
Electronic push button controls	10A electrical connection
LED display	



## TDX6SS-6 60cm Freestanding Dishwasher

### Key Features

---

Stainless steel finish	Child lock
14 place settings	Foldable bottom plate racks
6 washing programs + 2 auxiliary functions	Half load wash function
3 / 6 / 9 hour delay start	Anti flood protection
Electronic push button controls	49dB noise level
LED indicator lights	3 star energy rating
Extra dry function	4.5 star WELS rating, (per 12.5 litre wash)
Variable position cutlery basket	10A electrical connection
Easy-lift upper basket	



## TDX7SS-6 60cm Freestanding Dishwasher

### Key Features

---

Stainless steel finish	Foldable bottom plate racks
14 place settings	Half load wash function
7 washing programs + 3 auxiliary functions	Child lock
1 - 24 hour delay start	Anti flood protection
Electronic push button controls	49dB noise level
LED display	3.5 star energy rating
Extra dry function	4.5 star WELS rating, (per 12.5 litre wash)
Slideout third layer cutlery tray	10A electrical connection
Easy-lift upper basket	



## **TDX4INT-5** 45cm Integrated Dishwasher

### Key Features

---

Stainless steel finish	Child lock
9 place settings	Foldable bottom plate racks
6 washing programs + 2 auxiliary functions	Half load wash function
3 / 6 / 9 hour delay start	Anti flood protection
Electronic push button controls	49dB noise level
LED indicator lights	3 star energy rating
Extra dry function	4 star WELS rating, (per 9.4 litre wash)
Variable position cutlery basket	10A electrical connection
Easy-lift upper basket	



## **TDX8SS-6** 60cm Fully Integrated\* Dishwasher

### Key Features

---

Stainless steel finish	Foldable bottom plate racks
14 place settings	Child lock
8 washing programs + 1 auxiliary function	Anti flood protection
1 - 24 hour delay start	49dB noise level
Electronic push button controls	3.5 star energy rating
LED display	4.5 star WELS rating, (per 12 litre wash)
Extra dry function	10A electrical connection
Slideout third layer cutlery tray	

\*Does not include door panel



# LAUNDRY FEATURES AND BENEFITS

## ADD A GARMENT

Our front loading washing machine allows you to add or remove clothing from your load once the wash cycle has started, and when safe water and temperature levels have been reached.

## CONVENIENCE

"My Cycle" feature enables you to customise and save your favourite washing or drying program to suit your lifestyle needs.

## DESIGN & STYLE

Our washing machines and dryers are designed to suit your style. With side by side or stackable installation options, our matching washer and dryer pair will look great in any laundry.



## **TFL7W** 7kg Front Load Washing Machine

### Key Features

---

- |   |  |
|---|--|
| White finish  | LED display                              |
| 7kg washing capacity  | Fast+ function                           |
| 15 wash programs  | Anti-crease function                     |
| Spin speeds (RPM):<br>1200 - 1000 - 800 -<br>600 - Rinse Hold | 1 - 24 hour delay start                  |
| Temperature settings:<br>20 - 30 - 40 - 60 - 90               | Child lock & pause mode                  |
| Quick 14min wash program                                      | 3.5 star energy rating                   |
|   | 4 star WELS rating                       |
|   | Stacking kit model no. ESK<br>(optional) |



## **TCD7W** 7kg Front Load Condenser Dryer

### Key Features

---

- |                         |  |
|-------------------------|--|
| White finish            | 1 - 24 hour delay start                  |
| 7kg drying capacity     | Child lock                               |
| 15 drying programs      | 2 star energy rating                     |
| Auto-sensing drying     | Plumbed or tank drainage option          |
| LED progress indicators | Stacking kit model no. ESK<br>(optional) |
| Anti-crease function    |  |



## **TVD7U** 7kg Vented Dryer

### Key Features

---

- |                         |                           |
|-------------------------|---------------------------|
| White finish            | Pause feature             |
| 7kg drying capacity     | Large viewing window      |
| LED indicators          | Front air vent            |
| 180° door opening       | Lint filter display       |
| Anti wrinkle technology | 2 star energy rating      |
| Delay start option      | 10A electrical connection |
| Child lock              |                           |



**INSTALLATION**  
DRAWINGS

## 60cm Models

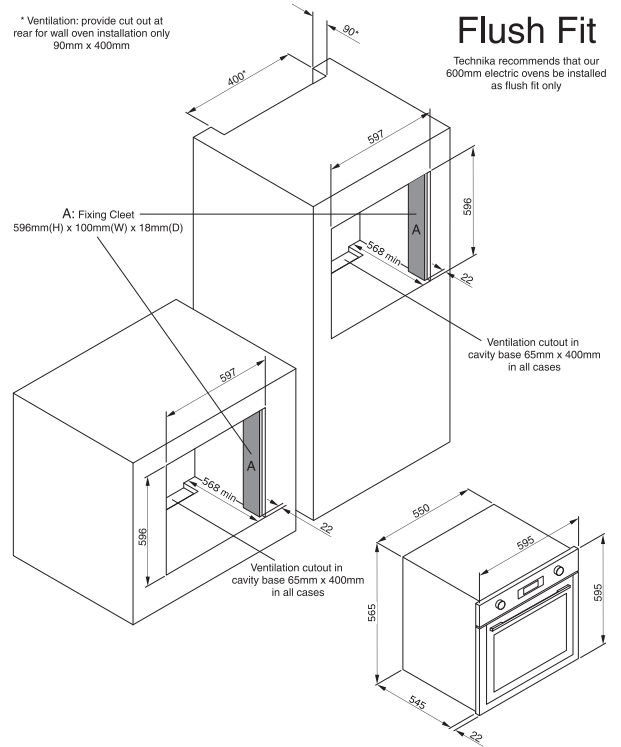
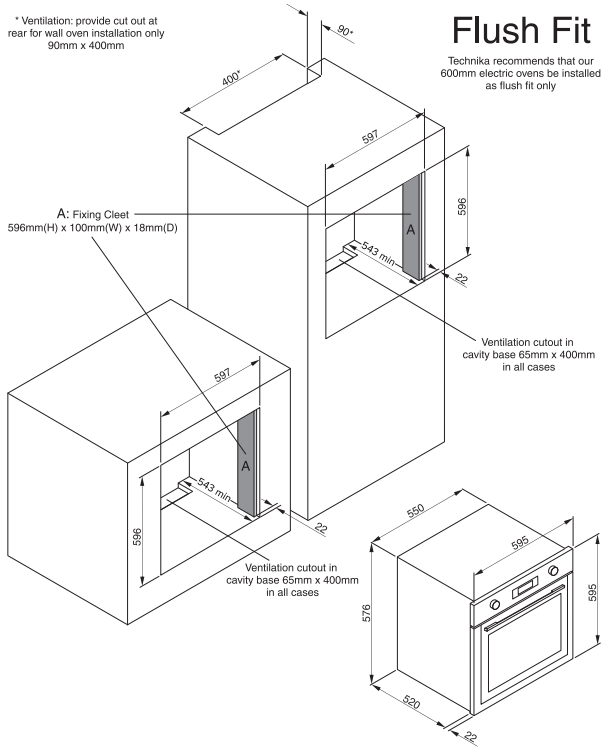

Model		Page
TO605TX	5 Function, Stainless Steel + Black Glass	6
TO610TBX	10 Function, Dark Stainless Steel + Black Glass	6
TO615AFBX	15 Function, Dark Stainless Steel + Black Glass	6
TGPO611ABK	11 Function, Dark Stainless Steel + Black Glass	7

### Dimensions (W x H x D)

Product	595 x 595 x 542mm
Cut-out	597 x 596 x 543mm

Model		Page
TSO605TX-R	5 Function, Dark Stainless Steel + Black Glass	7
TSO605TX-L	5 Function, Dark Stainless Steel + Black Glass	7

### Dimensions (W x H x D)

Product	595 x 595 x 567mm
Cut-out	597 x 596 x 568mm

## 90cm Models

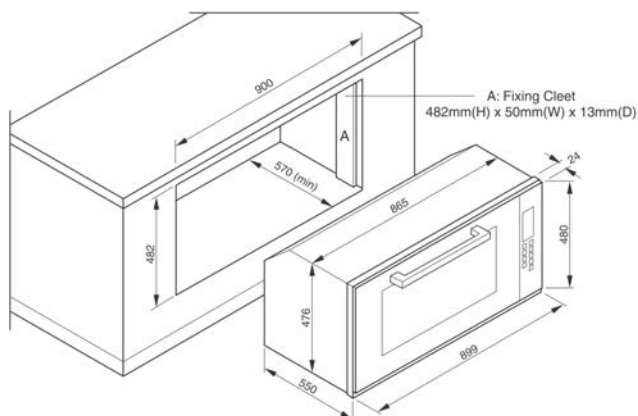

Model		Page
TTDT910-6	10 Function, Dark Stainless Steel + Black Glass	8
T948SS-6	10 Function, Stainless Steel + Black Glass	8

### Dimensions (W x H x D)

Product	899 x 480 x 550mm
Cut-out	900 x 482 x 570mm

# UPRIGHT COOKERS

## 60cm Models

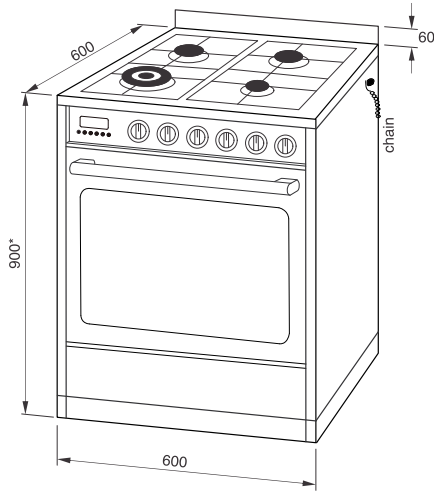

Model		Page
<b>T640TE8</b>	8 Function, Stainless Steel	10

### Dimensions (W x H x D)

Product	600 x 900* x 600mm
Cut-out	602 x 900* x 600mm

\* Plus levelling feet (10mm minimum)

## 90cm Models

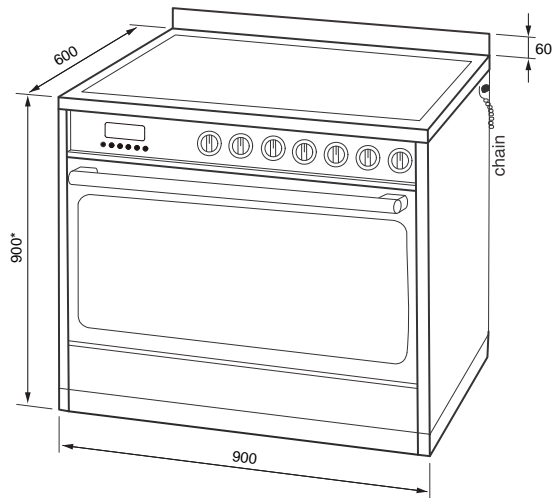
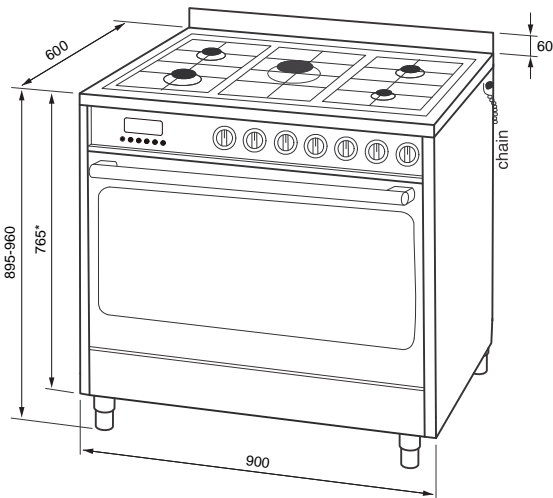

Model Numbers		Page
<b>GHE09TDSS-4</b>	8 Function, Stainless Steel	10

### Dimensions (W x H x D)

Product	900 x 765* x 600mm
Cut-out	902 x NA x 600mm

\* Plus levelling feet (10mm minimum) (for optional shelf installation)

Model		Page
<b>TU950TME8</b>	8 Function, Stainless Steel	11
<b>TU950TLE8</b>	8 Function, Stainless Steel	11
<b>TU950TME8BG</b>	8 Function, Stainless Steel + Black Glass	12
<b>TU950TLE8G</b>	8 Function, Stainless Steel + Black Glass	12
<b>TEG95TBK</b>	8 Function, Matte Black + Stainless Steel	13
<b>CERHE09PSS-2</b>	8 Function, Stainless Steel	13

### Dimensions (W x H x D)

Product	900 x 900* x 600mm
Cut-out	902 x 900* x 600mm

\* Plus levelling feet (10mm minimum)

**Note:** Cooktop burners / zone positioning for each model listed above are different. Please see each individual image for actual cooktop burner / zone positioning.



## 30cm Gas Models

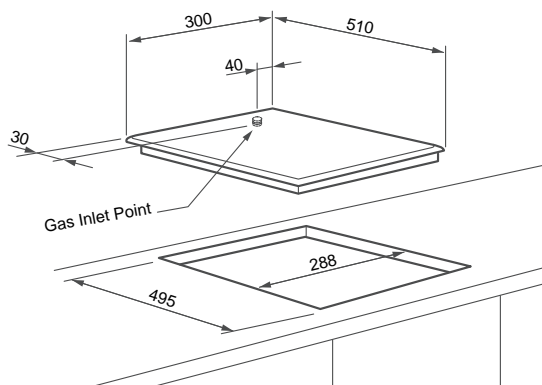

Model		Page
H320SXFFPRO-2	2 Burner, Stainless Steel	15

### Dimensions (W x H x D)

Product	300 x 52 x 510mm
Cut-out	288 x 40 x 495mm

## 60cm Gas Models

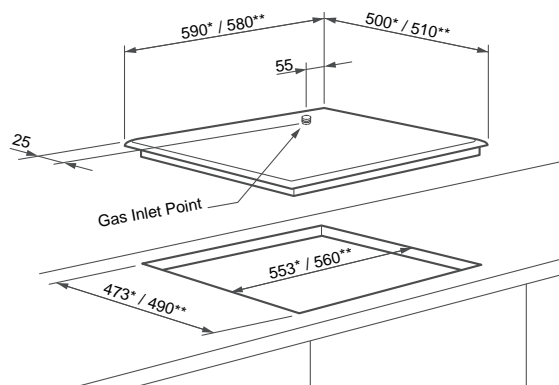

Model		Page
H640STXFPRO-3*	4 Burner, Stainless Steel	15
TGC6GWFFS**	4 Burner, Stainless Steel	15
TGC6GWBGFS**	4 Burner, Black Glass + Stainless Steel	15

### Dimensions (W x H x D)

Product	590* / 580** x NA x 500* / 510**mm
Cut-out	553* / 560** x NA x 473* / 490**mm

## 90cm Gas Models

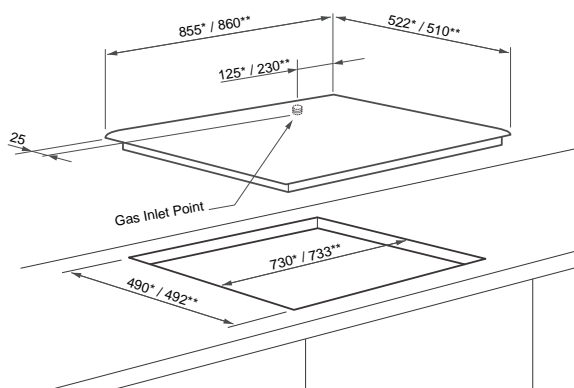

Model		Page
TGC9GLWFSS*	5 Burner, Stainless Steel	16
TGC9GLWBGFS*	5 Burner, Black Glass + Stainless Steel	16
H950STXFPRO**	5 Burner, Stainless Steel	16
H950SLTXFPRO**	5 Burner, Stainless Steel	17

### Dimensions (W x H x D)

Product	855* / 860** x 60* / 52** x 522* / 510**mm
Cut-out	730* / 733** x 40* / 40** x 490* / 492**mm

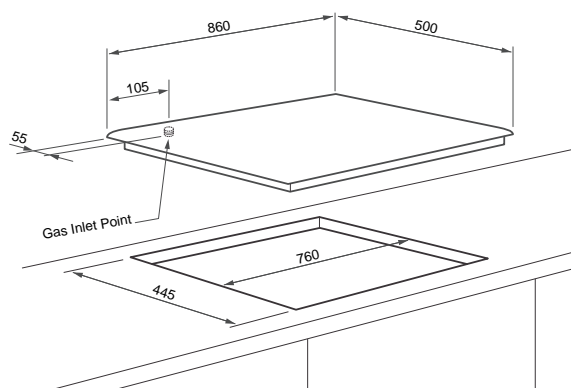

Model		Page
H950STBGFFPRO	5 Burner, Black Glass	17

### Dimensions (W x H x D)

Product	860 x 52 x 500mm
Cut-out	760 x 40 x 445mm

Note: Cooktop burners and controls for each model listed above are different. Please see each individual image for actual cooktop burner and control positioning.

## 30cm Ceramic Models

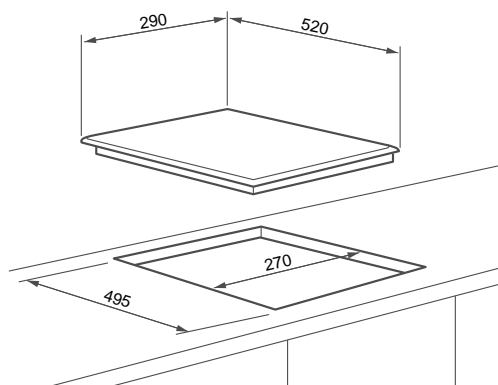

Model		Page
<b>2RSS-5</b>	2 Zone, Premium Schott-Ceran Glass	18

### Dimensions (W x H x D)

Product	290 x 50 x 520mm
Cut-out	270 x 46 x 495mm

## 60cm Ceramic Models

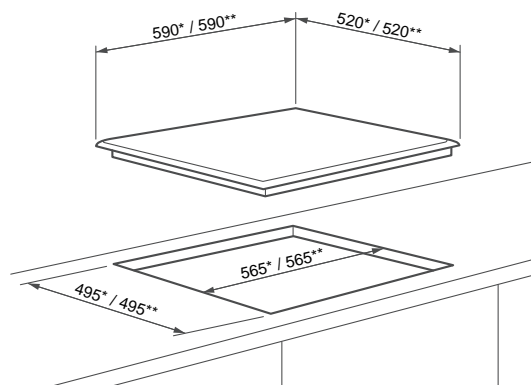

Model		Page
<b>CFM641-5*</b>	4 Zone, Glass	18
<b>CFE641-5*</b>	4 Zone + 1 Extendable Zone, Glass	18
<b>TGC6IND-5**</b>	4 Zone + 1 Extendable Zone, Glass	19

### Dimensions (W x H x D)

Product	590* / 590** x 50* / 58** x 520* / 520**mm
Cut-out	565* / 565** x 46* / 54** x 495* / 495**mm

## 90cm Ceramic Models

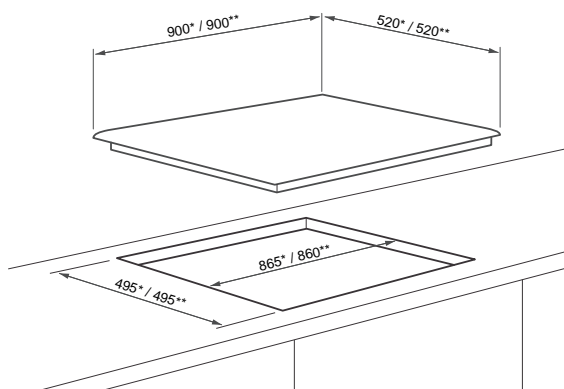

Model		Page
<b>95HTSS-5*</b>	5 Zone + 2 Extendable Zone, Glass	19
<b>TGC9IND-5**</b>	6 Zone + 2 Flexi-Zone + 1 Extra Large Zone	19

### Dimensions (W x H x D)

Product	900* / 900** x 50* / 58** x 520* / 520**mm
Cut-out	865* / 860** x 46* / 54** x 495* / 495**mm

Note: Cooktop zone positioning and controls for each model listed above are different. Please see each individual image for actual cooktop zone and control positioning.

# RANGEHOODS

## 60cm Slideout Models

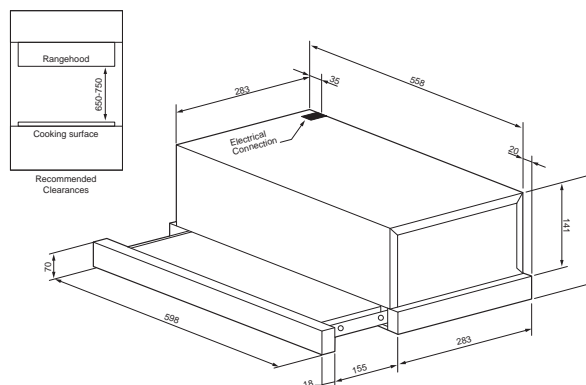
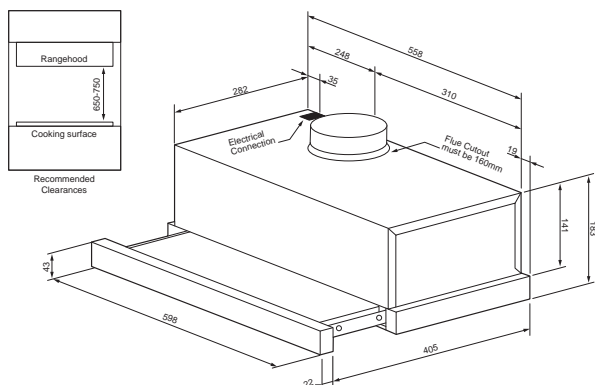

Model		Page
SL10160I-4	Slideout, Stainless Steel	23
SL2026ISS-3	Slideout, Stainless Steel	23

Model		Page
SREC0160I-2	Recirculating Slideout, Stainless Steel	23

### Dimensions (W x H x D)

Product	598 x 183 x 282mm
Cut-out	600 x 185 x 304mm

### Dimensions (W x H x D)

Product	598 x 183 x 283mm
Cut-out	600 x 183 x 301mm

## 90cm Slideout Models

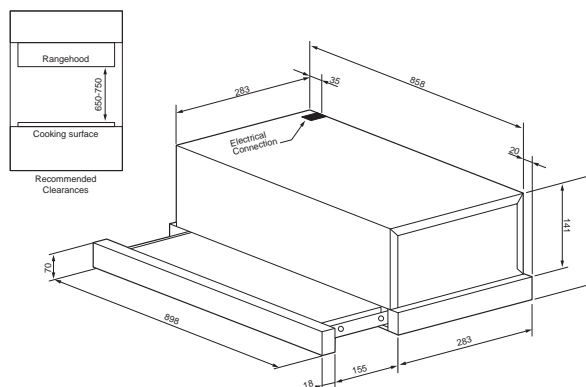
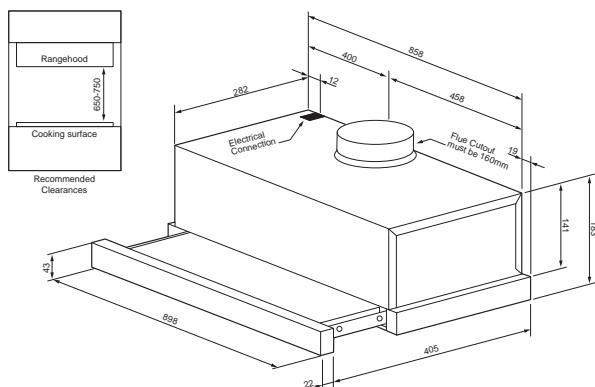

Model		Page
SL10190ISS-4	Slideout, Stainless Steel	24
SL10290ISS-3	Slideout, Stainless Steel	24

Model		Page
SREC0190SS-2	Recirculating Slideout, Stainless Steel	24

### Dimensions (W x H x D)

Product	898 x 183 x 282mm
Cut-out	900 x 183 x 304mm

### Dimensions (W x H x D)

Product	898 x 183 x 300mm
Cut-out	900 x 183 x 300mm

## 60cm Canopy Models

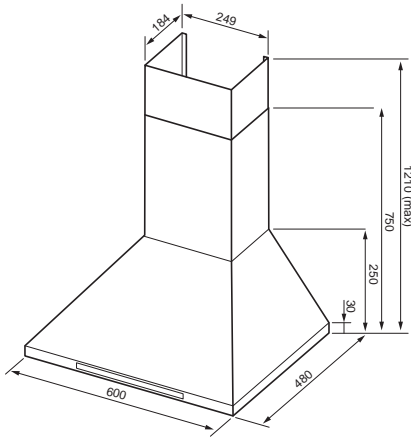

Model		Page
<b>CHEM52C6S-5</b>	Pyramid Canopy, Stainless Steel	25

### Dimensions (W x H x D)

Product	600 x 1210 x 480mm
Cut-out	600 x NA x 480mm

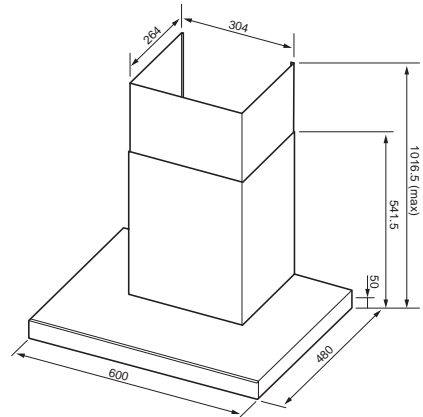

Model		Page
<b>FHEE22A6S-5</b>	Deluxe Canopy, Glass + Stainless Steel	25

### Dimensions (W x H x D)

Product	600 x 1016.5 x 485mm
Cut-out	600 x NA x 485mm

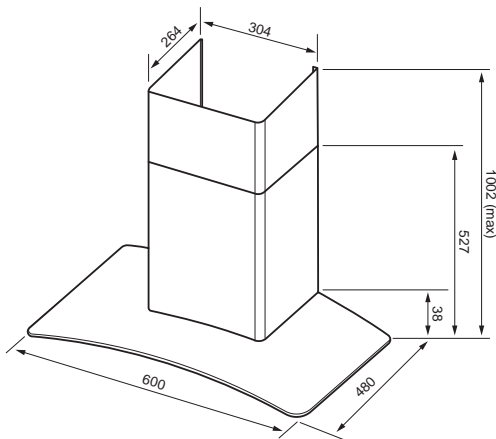

Model		Page
<b>BG96A6-5</b>	Curved Canopy, Glass + Stainless Steel	25

### Dimensions (W x H x D)

Product	600 x 1002 x 480mm
Cut-out	600 x NA x 480mm

## 90cm Canopy Models

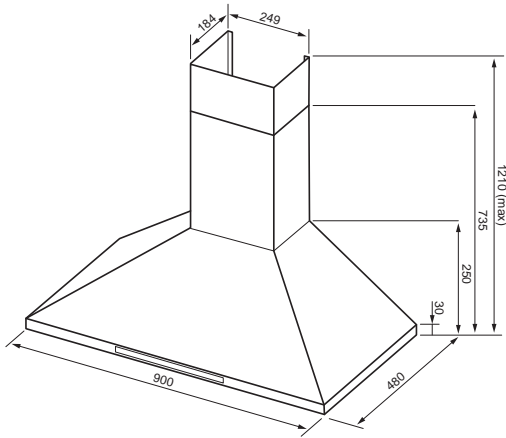

Model		Page
CHEM52C9S-5	Pyramid Canopy, Stainless Steel	26
CHEM52TLX	Pyramid Canopy, Stainless Steel	26

### Dimensions (W x H x D)

Product	900 x 1210 x 480mm
Cut-out	900 x NA x 480mm

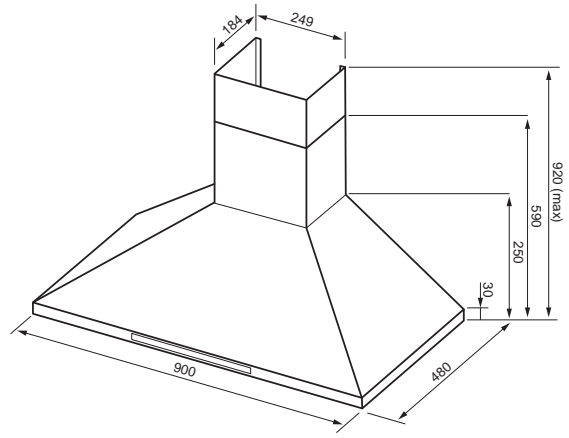

Model		Page
CHEM52C9CL-5	Short Flue Pyramid Canopy, Stainless Steel	26

### Dimensions (W x H x D)

Product	900 x 920 x 480mm
Cut-out	900 x NA x 480mm

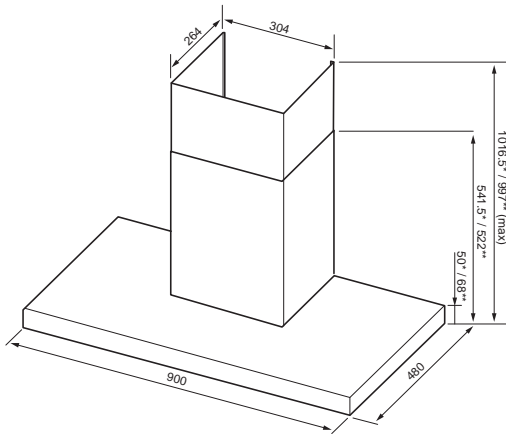

Model		Page
FHEE22A9S-5*	Canopy, Stainless Steel	27
FHEE26A9S-5**	Canopy, Stainless Steel + Glass Top	27

### Dimensions (W x H x D)

Product	900* / 900** x 1016.5* / 997** x 480* / 480**mm
Cut-out	900* / 900** x NA* / NA** x 480* / 480** mm

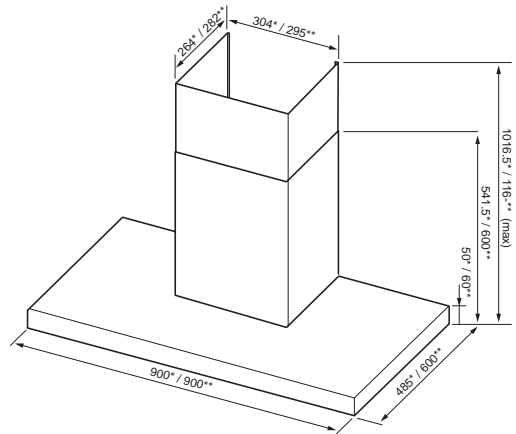

Model		Page
FHEE229SC9S-5*	Deluxe Canopy, Stainless Steel + Glass	27
ICF9BLS**	Flat Island Canopy, Stainless Steel + Glass	28

### Dimensions (W x H x D)

Product	900 x 1016.5 x 485mm
Cut-out	900 x NA x 485 mm

## 90cm Canopy Models

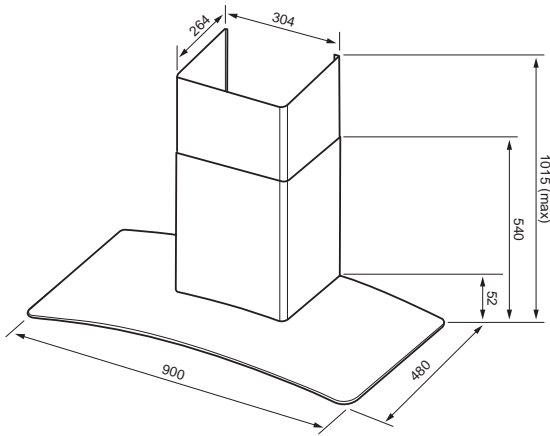

## 120cm BBQ Models

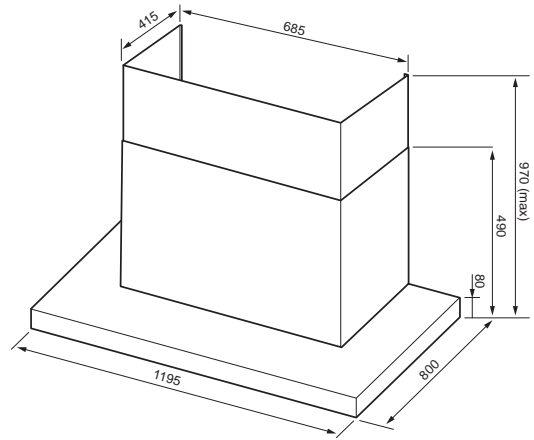

Model		Page
<b>FHEE91A9S-5</b>	Deluxe Curved, Stainless Steel + Glass	28

### Dimensions (W x H x D)

Product	900 x 1015 x 480mm
Cut-out	900 x NA x 480mm

Model		Page
<b>TAR1200S</b>	Alfresco BBQ, Stainless Steel	28

### Dimensions (W x H x D)

Product	1195 x 970 x 800mm
Cut-out	1195 x NA x 800mm

## 28L Models

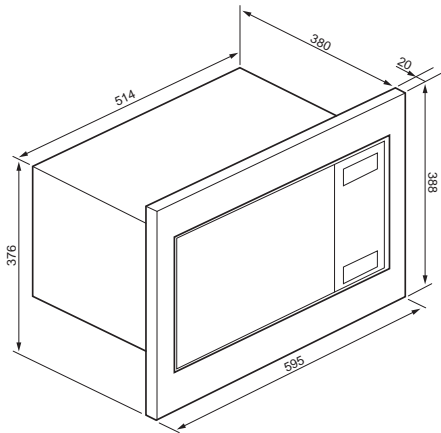

Model		Page
WD905-2	Stainless Steel	30
BD28MBK	Black Stainless Steel	30

### Dimensions (W x H x D)

Product	595 x 388 x 400mm
Cut-out	600 x 390 x 540mm

**Ventilation: Option 1**  
Cutout 45mm x 500mm top rear of cabinet

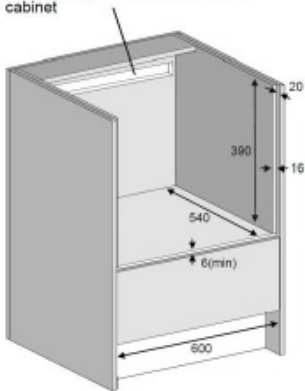

**Ventilation: Option 2**  
140mm x cabinet width vented down into kick panel space

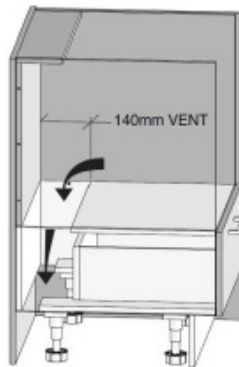

**Ventilation: Option 3 (for tower installation)**  
45mm x cabinet width vented to top of cabinetry / into roof cavity.

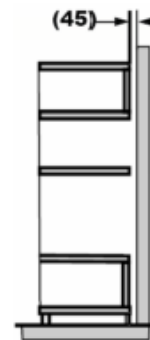

# DISHWASHERS

## 55cm Compact Models

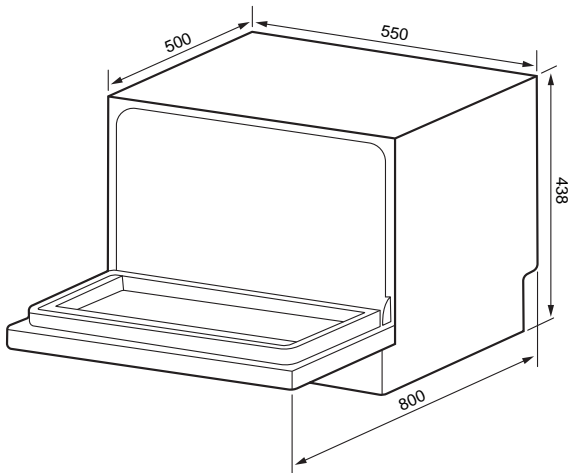

Model		Page
TEBTDWS-5	Compact, Stainless Steel	32

### Dimensions (W x H x D)

Product	550 x 438 x 500mm
Cut-out	552 x 440 x 500mm

## 60cm Freestanding Models

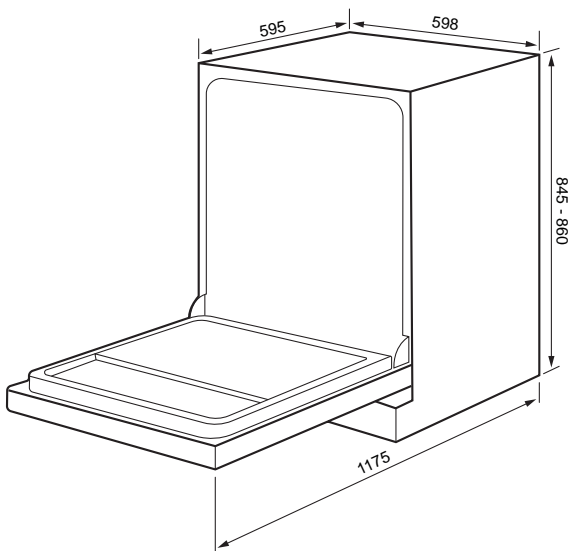

Model		Page
TDX6SS-6	Freestanding, Stainless Steel	32
TDX7SS-6	Freestanding, Stainless Steel	32

### Dimensions (W x H x D)

Product	598 x 845 x 600mm
Cut-out	600 x 850 - 870 x 600mm



## 45cm Integrated Models

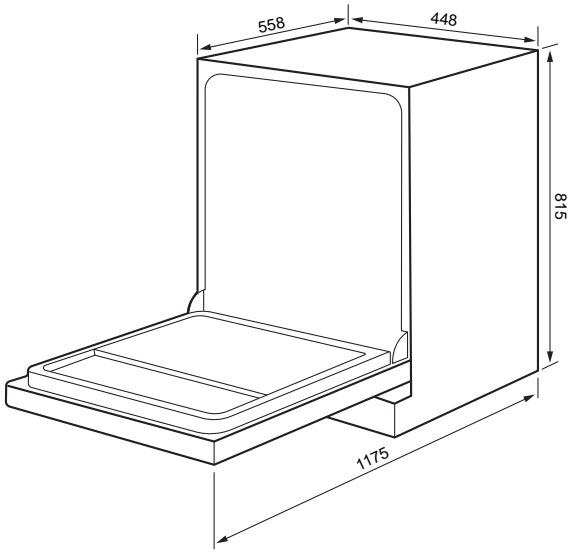

Model		Page
TDX4INT-5	Integrated, Stainless Steel	33

### Dimensions (W x H x D)

Product	448 x 815 x 558mm
Cut-out	450 x 817 - 875 x 580mm

## 60cm Integrated Models

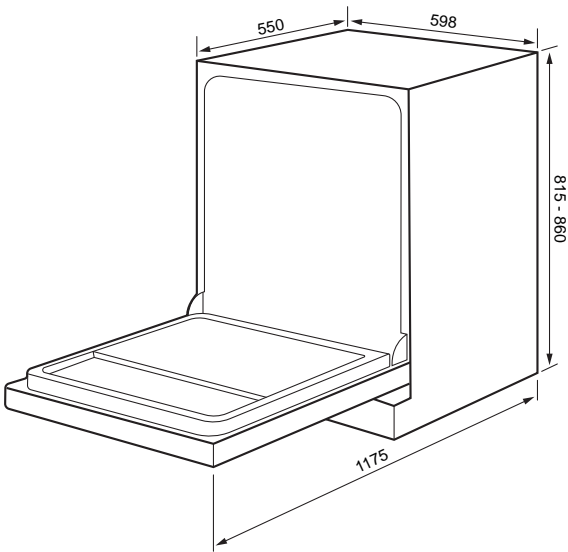

Model		Page
TDX8SS-6	Integrated, Stainless Steel	33

### Dimensions (W x H x D)

Product	598 x 815 x 550mm
Cut-out	600 x 820 x 580mm

Washing Machines

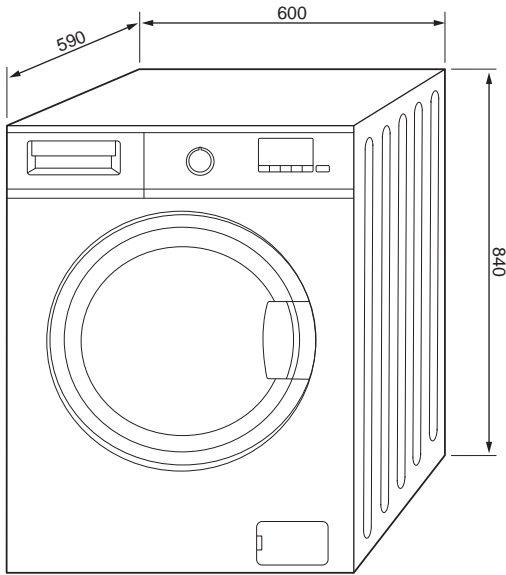

Model		Page
TFL7W	Front Loading Washing Machine, White	35

Dimensions (W x H x D)

Product	600 x 840 x 590mm
---------	-------------------

Dryers

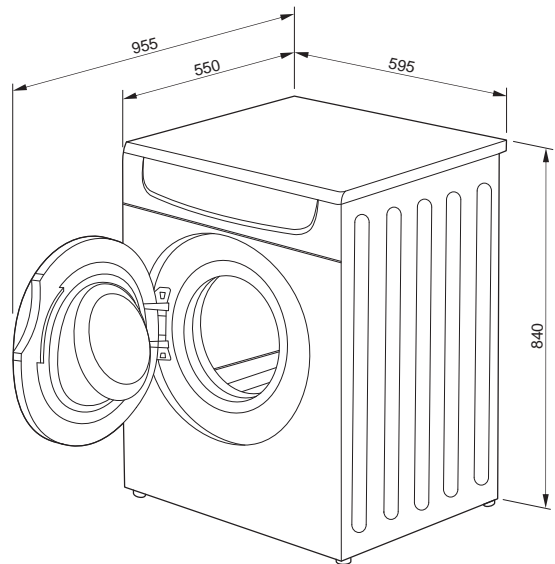
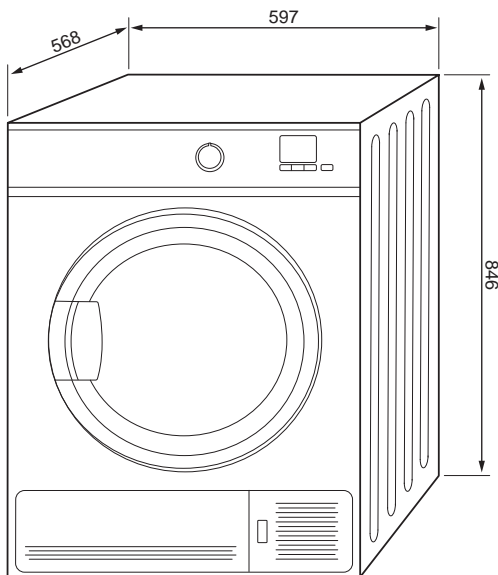

Model		Page
TFL7W	Front Loading Condenser Dryer, White	35

Dimensions (W x H x D)

Product	597 x 846 x 568mm
---------	-------------------

Model		Page
TVD7U	7kg Vented Dryer, White	35

Dimensions (W x H x D)

Product	595 x 840 x 550mm
---------	-------------------

# WARRANTY

---

Technika constantly seeks ways to improve the specifications and design of its products. Whilst every effort is made to produce up to date literature, this brochure should not be regarded as an infallible guide. Actual product only should be used to derive cut-out sizes.

## Installation warning

Incorrect installation of any product will void all warranty.

## Note

All dimensions on these pages are in millimetres and the illustrations are intended as a guide only. Complete instructions are enclosed with the appliance or can be obtained by contact the customer care centre on toll free 1800 444 357 or by email: [commercialcare.ha@glendimplex.com.au](mailto:commercialcare.ha@glendimplex.com.au)

All rangehoods are supplied with a complete mounting kit, easy to follow instructions, and can be plugged into a standard power point. All rangehoods must be installed in accordance with local building regulations. For optimum performance Technika recommends that rangehoods be installed between 650mm and 750mm above the highest point of the cooking surface. The rangehood must not be any lower than 600mm from the highest point of the cooking surface as per AS/NZS 5601.

## Product support and service

Technika has an extensive national service network. Please contact our national customer care toll free on 1800 444 357 (press 4 for commercial customer care) or by emailing [commercialcare.ha@glendimplex.com.au](mailto:commercialcare.ha@glendimplex.com.au) for any enquiries.

## Caution

All ovens have been tested and approved to the relevant Australian Standards. Where the oven is built in or close to a cabinet, the cabinet material must be capable of withstanding 75 degrees °C. Technika will not accept responsibility for incorrect installation into low temperature tolerant cabinets. Please contact Technika's national customer care line for installation details toll free 1800 444 357 or by email: [commercialcare.ha@glendimplex.com.au](mailto:commercialcare.ha@glendimplex.com.au)

## Warranty

All Technika appliances carry a 3 year parts and labour warranty, excluding consumables i.e globes.

Natural gas regulators are provided with all gas appliances as per the Australian Standard requirement and carry a 12 month warranty only.

All appliances that incorporate electronic components (i.e. programmable clocks and electronic switching) should be fitted with a surge protection device to guard against damage which can be caused by power fluctuations or surges.

This warranty does not cover damage caused by such events.

For more information on all **TECHNIKA** appliances,  
or for dimension and installation information, phone  
or email our customer care team or visit our website:

**technika.com.au**

**HEAD OFFICE**

8 Lakeview Drive, Scoresby VIC 3179

**THE KITCHEN APPLIANCE SHOWROOM**

1/239 Ferntree Gully Road, Mount Waverly VIC 3149

1800 444 357

commercialcare.ha@glendimplex.com.au

www.glendimplex.com.au

We reserve the right to make changes to specifications and dimensions without notice. Technika is imported and serviced by Glen Dimplex Australia who reserve the right to adjust and modify products in this brochure without prior notification. Some images in this brochure may be indicative. Please refer to individual product user manuals for full installation details.

