

TGO910FTBS

90CM ELECTRIC MULTI-FUNCTION OVEN

TECHNIKA

PROFESSIONAL SERIES

Features

105L capacity

10 functions + Rotisserie

Fast preheat + Memory settings

Stainless steel finish

Sensor touch controls

LED display

4 shelf positions

Closed door grilling

2 oven lights

Programmable timer + minute minder

Child lock

Durable easy clean blue enamel interior

Removable triple glazed door

Removable inner glass door panels

Cavity cooling system

2 year warranty

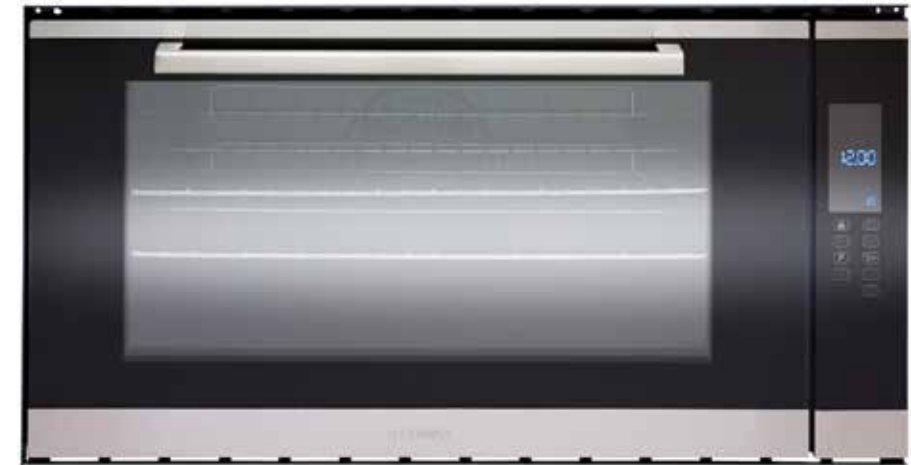

TGO910FTBS

90CM ELECTRIC MULTI-FUNCTION OVEN

TECHNIKA

PROFESSIONAL SERIES

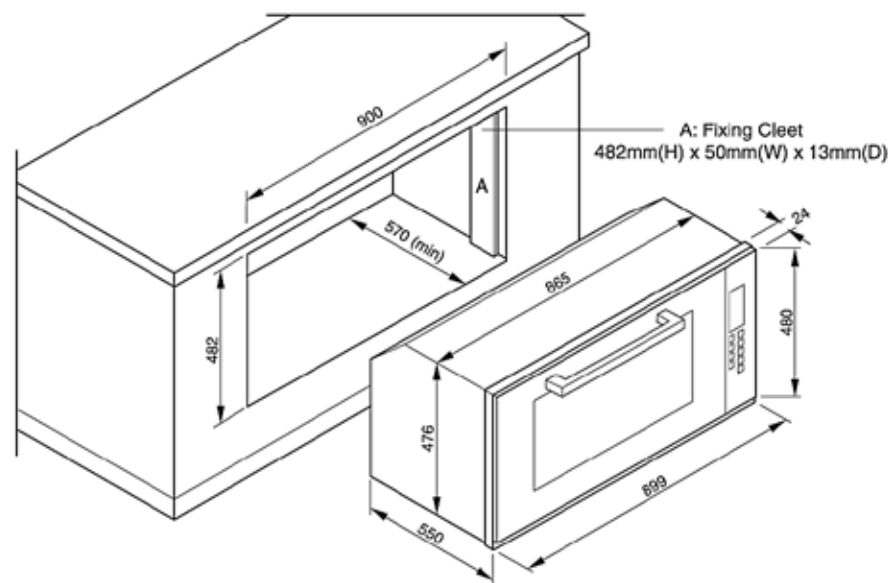

TGO910FTBS		
Type	Multi-function oven	
Fuel	Electric	
OVEN FUNCTIONS		
Full grill	Yes	
Fan grill	Yes	
Conventional	Yes	
Fan assist	Yes	
Fan forced	Yes	
Top heat	Yes	
Base heat + fan	Yes	
MultiCooking	Yes	
Pizza	Yes	
Defrost	Yes	
Fast preheat	Yes	
Memory	Yes	
OVEN FEATURES		
Gross capacity (L)	105	
Controls	Sensor touch	
No. of shelves	2	
No. of shelf positions	4	
Lights	2	
Safety switch-off	Yes	
Door opening	Drop-down	
TIMER		
Minute minder	Yes	
Programmable timer	Yes	
Child lock	Yes	
ACCESSORIES (INCLUDED)		
Grill tray with wire rack	1	
Rotisserie kit	1	
INSTALLATION		
Electrical connection	15A hardwire	
Power	220 – 240V / 50Hz	
Cavity cooling system	Yes	
DIMENSIONS (W x H x D)		
Product (mm)	899 x 480 x 550	
Cut out (mm)	900 x 482 x 570	