

USER GUIDE  
**CONCEALED UNDERMOUNT  
SINGLE SPEED RANGEHOOD**  
TSSUR52S

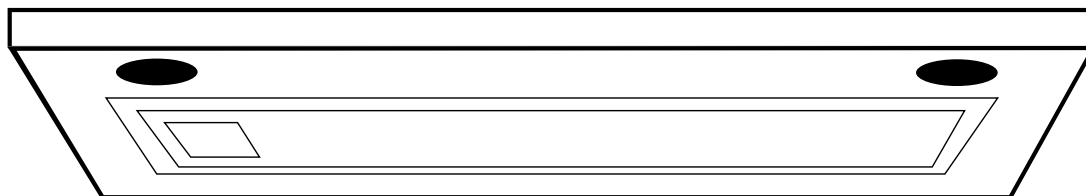



---

# CONTENTS TABLE

---

## **For Your Safety**

|                         |   |
|-------------------------|---|
| Safety Precautions_____ | 3 |
| Before Connecting_____  | 3 |
| Warnings_____           | 4 |

## **Use and Care**

|                              |   |
|------------------------------|---|
| Use and Care_____            | 6 |
| Controls_____                | 6 |
| Cleaning your Rangehood_____ | 7 |
| Troubleshooting_____         | 8 |
| Disposal_____                | 8 |

## **Installation**

|                                    |    |
|------------------------------------|----|
| Electrical Connection_____         | 9  |
| Instructions for Installation_____ | 10 |
| Dimensions_____                    | 10 |
| Warranty_____                      | 12 |

Carefully read the following important information regarding installation safety and maintenance. Keep this information booklet accessible for future reference.

The appliance has been designed for use in a Ducted installation.

### **Safety Precautions**

Take care when the Range Hood is operating simultaneously with an open fireplace or burner that depend on natural ventilation as the Range Hood removes air from the room, which a burner or fireplace may need for combustion.

Provide adequate ventilation for safe operation of the Range Hood. Follow any local laws that apply to external air evacuation.

### **Before connecting to the electricity network:**

Look at the data plate (located inside the appliance) to ascertain that the voltage and power correspond to the available power supply and the power outlet is suitable. If in doubt ask a qualified electrician.

If the appliance is used intensively for a long period of time, you may need to open a window to improve airflow.

### WARNINGS!

---

- Do not check the status of the filters while the Range Hood is operating.
- Do not touch bulbs or adjacent areas, during or straight after use.
- **CAUTION:** Accessible parts may become hot when used with cooking appliances.
- Do not flambé under the Range Hood.
- Avoid free flame, as it is damaging to the filters and can cause fire hazard.
- Constantly check food frying, overheated oil may become a fire hazard.
- Disconnect the electrical plug prior to any maintenance.
- This appliance is not intended for use by persons (including children) with reduced physical, sensory or mental capabilities, or lack of experience and knowledge, unless they have been given supervision or instruction concerning use of the appliance by a person responsible for their safety.
- Children should be supervised to ensure that they do not play with the appliance.
- There shall be adequate ventilation in the room when the Range Hood is used at the same time as appliances burning gas or other fuels.
- There is a fire risk if cleaning is not carried out in accordance with the instructions.
- **WARNING:** DO NOT penetrate any screws into the range hood as this may result in electrical hazards.
- **WARNING:** Failure to install the screws or fixing device in accordance with these instructions may result in electrical hazards.
- If the supply cord is damaged, it must be replaced by the manufacturer, its service agent or similarly qualified persons in order to avoid a hazard.
- The air must not be discharged into a flue that is used for exhausting fumes from appliances burning gas or other fuels.
- The minimum distance between the cooktop hob and the lowest part of the range hood shall be at least 60cm. If the instructions for installation of the gas hob specify a greater distance, this has to be taken into account.
- Regulation concerning the discharge of air has to be fulfilled.
- 52cm rangehoods can only be installed above hobs with 4 or less burners / elements.
- 70cm rangehoods can only be installed above hobs with 5 or less burners / elements.
- 90cm rangehoods can only be installed above hobs with 6 or less burners / elements.

THE MANUFACTURER DECLINES ALL RESPONSIBILITY FOR DAMAGES CAUSED BY BREACHING THE ABOVE WARNINGS.

#### LED Lamps

LED lamp assemblies are a spare part and are not repairable or replaceable by the customer. If an LED lamp fails, it must be replaced by a suitably qualified technician.

Please call Glen Dimplex after sales service.

To ensure the Range Hood continues to operate effectively, regular maintenance and cleaning is required. Clean the fan and other surfaces of the Range Hood regularly using a cloth moistened with warm water or non-abrasive liquid detergent.

### **Controls**

This rangehood has a single speed motor and is designed to be operated via the power point or an isolation switch.

When the power is connected, the fan and light will operate at all times.

When the power is switched off, the fan and light will switch off.

Please see Electrical Connection on page 9 for further details.

### Cleaning your rangehood

---

The proper function of the rangehood requires regular maintenance operations.

The anti-grease filters capture the grease particles suspended in the air, and are therefore subject to clogging according to the frequency of the use of the appliance.

In order to prevent fire hazard, it is recommendable to clean the filter at a minimum of every 2 months by carrying out the following instructions:

- Remove the filters from the cooker hood and wash them in a solution of water and neutral liquid detergent, leaving to soak.
- Rinse thoroughly with warm water and leave to dry.
- The filters may also be washed in the dishwasher.

The aluminum panels may alter in color after several washes. This is not cause for customer complaint nor replacement of panels.

Clean the fan and other surfaces of the cooker hood regularly using a cloth moistened with denatured alcohol or non abrasive liquid detergent.

Keep motor and other parts free from water as this will cause damage to the appliance.

### Troubleshooting

---

| Problem                             | Possible reason                          | Solution   |
|-------------------------------------|--|--|
| Hood doesn't work                   | No electricity supply                    | Check the plug is connected  |
|                                     |  | Check that the main switch/ circuit breaker/safety switch is turned on |
| Poor airflow                        | Aluminum grease filters clogged          | Clean the filters and replace when dry                                 |
| Motor running but no airflow        | Butterfly valve jammed                   | Contact service department   |
| Motor turns off after a few minutes | High temperature safety device activated | The kitchen is not sufficiently ventilated                             |
|                                     | The hood is installed near the cooktop   | The hood must be at least 600mm from the top of the cooktop            |
| Oil dripping onto stove             | Aluminum grease filter saturated         | Wash the aluminum grease filters                                       |
| Whirring sound                      | Something in contact with fan blade      | Contact service agreement  |



#### Disposal

By ensuring this product is disposed of correctly, you will help prevent potential negative consequences for the environment and human health, which could otherwise be caused by inappropriate waste handling of this product.

The symbol on the product indicates that this product may not be treated as household waste. Instead it shall be handed over to the applicable collection point for the recycling of electrical and electronic equipment.

Disposal must be carried out in accordance with local environmental regulations for waste disposal.

For more detailed information about treatment, recovery and recycling of this product, please contact your local city council office.



Assembly and electrical connections must be carried out by authorised personnel.

## Electrical Connection

The Range Hood is fitted with a power cord and 3 pin plug. Install the Range Hood so that the plug is easily accessible. Plug the 3- pin plug into a properly earthed, 10A general purpose power outlet.

If the supply cord is damaged, it must be replaced by the manufacturer or its service agent or a similarly qualified person in order to avoid a hazard.

The appliance has been manufactured as a class I, therefore earth cable is necessary.

The connection to the mains is carried out as follow:

|             | IEC227       | North America |
|-------------|--------------|---------------|
| L = Live    | Brown        | Black         |
| N = Neutral | Blue         | White         |
| E = Earth   | Green/Yellow | Green         |

## NOTE:

When controlling the rangehood to switch on and off with an electric cooktop, the power point may be controlled by an isolation switch in conjunction with the cooktop power.

In this case, the power point for the rangehood must still be accessible by the customer after installation.

It is the installer's responsibility to ensure and any relevant installation standards from the Wiring Rules AS/NZS3000 are adhered to.

An omnipolar switch with a minimum aperture of 3mm between contacts, in line with the electrical load and local standards, must be placed between the appliance and the network in the case of direct connection to the electrical network.

## Instructions for Installation

Install Range Hoods in accordance with the manufacturer's instructions. For optimum performance, we recommend that all Range Hood clearances be a minimum of 650mm to a maximum of 750mm between the top of the cooking surface to the underside of the Range Hood. The distance may be reduced to 600mm to align with AS/NZS 5601.

**WARNING:** DO NOT penetrate any screws into the range hood as this may result in electrical hazards.

**WARNING:** Failure to install the screws or fixing device in accordance with these instructions may result in electrical hazards.

| Recommended Clearances |         |
|------------------------|---------|
| Rangehood              | 650-750 |
| Cooking Surface        |         |

If a connection flue composed of two parts is used, the upper part must be placed outside the lower part.

Exhaust air must not be discharged into a flue which is used for exhausting fumes from appliances burning gas or other fuels.

Installation must comply with any local regulations concerning the discharge of exhaust air.

Before proceeding with the assembly, remove the anti-grease filter so that the unit is easier to handle. Prepare the hole in the ceiling or wall for the evacuation of the air.

## Dimensions

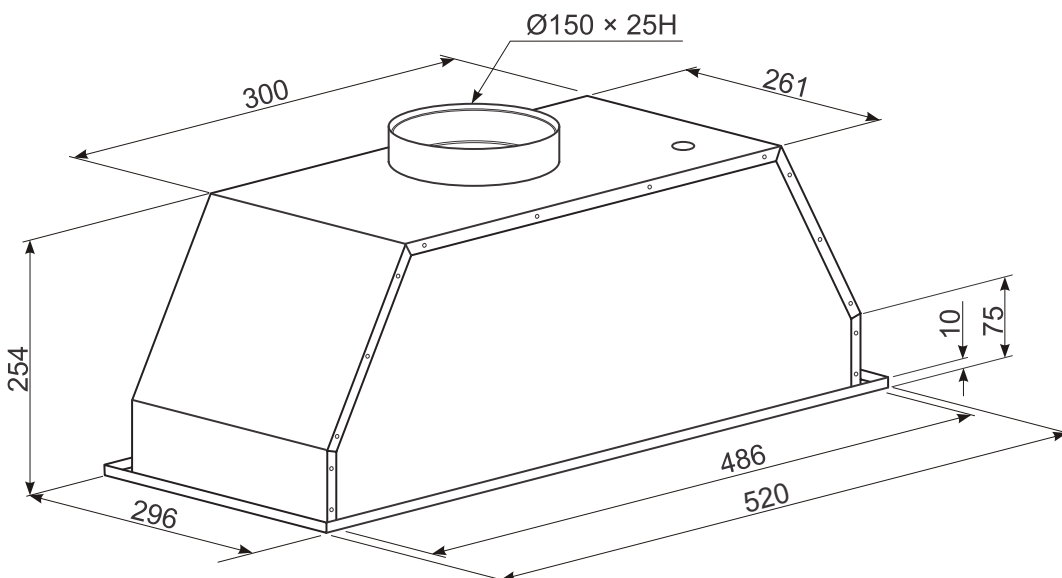

---

# INSTALLATION

---

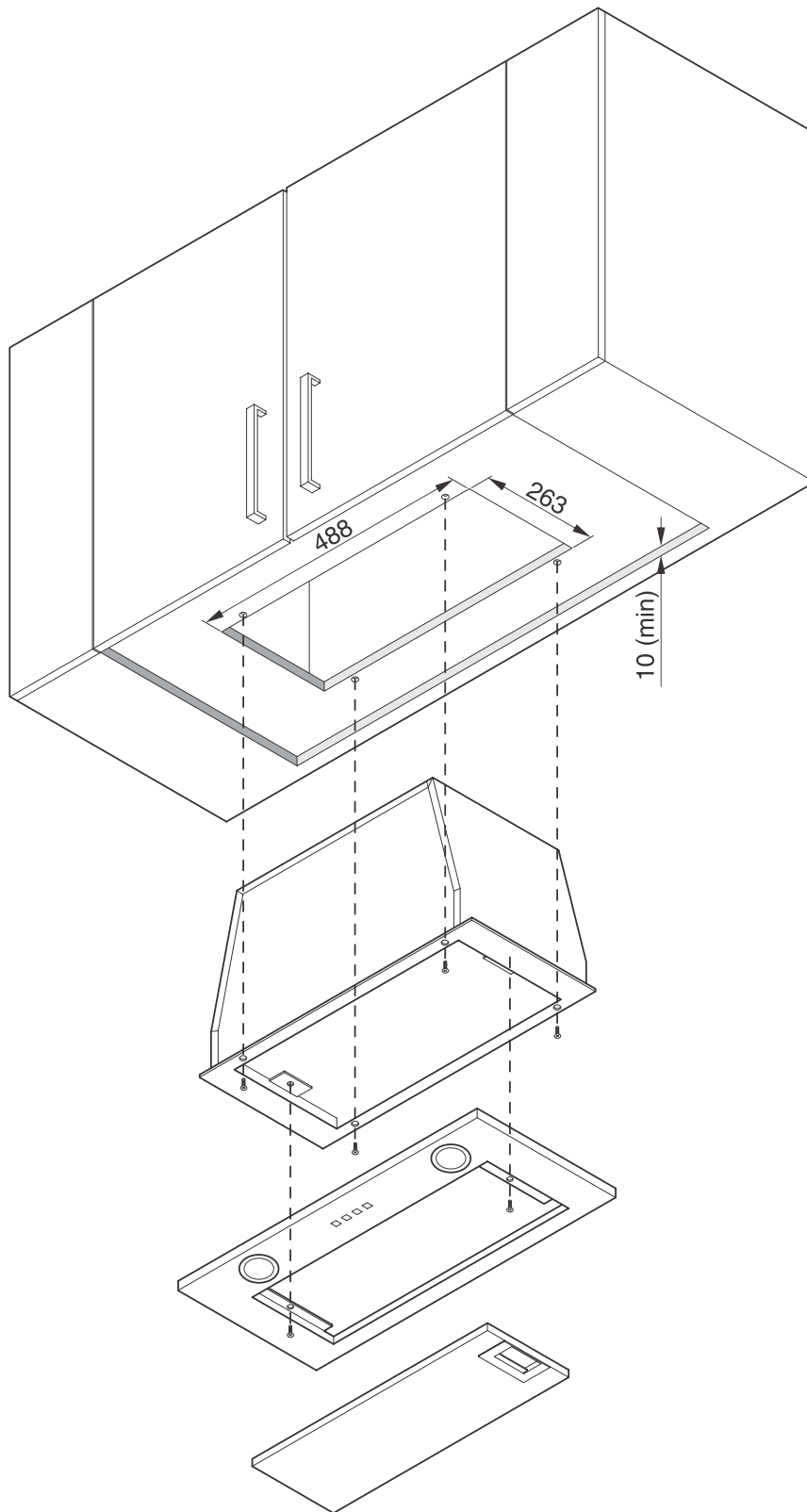

---

# MANUFACTURER GUARANTEE

---

This warranty is provided in Australia by Glen Dimplex Australia Pty Limited ABN 69 118 275 460 **(Phone number 1300 556 816)** and in New Zealand by Glen Dimplex New Zealand Limited NZBN 9429000069823 **(Phone number 09 274 8265)** in respect of the **Technika Professional** product.

## 1. Technika Professional Express Warranty

Subject to the exclusions below, we warrant that the product will not have any electrical or mechanical breakdowns within:

- a) In the case of **Technika Professional** products used for personal, domestic or household purposes, a period of 2 years from the date the product is purchased as a brand-new product from a retailer located in Australia / New Zealand.
- b) In the case of **Technika Professional** products used for purposes other than personal, domestic or household purposes (including business or commercial use), a period of 90 days from the date the product is purchased as a brand-new product from a retailer located in Australia / New Zealand. **Technika Professional** products are designed and intended for domestic use only; and
- c) All warranty repairs must be carried out by Glen Dimplex or their nominated service agent

**Note: warranty periods detailed above may vary in line with agreements with select retail and builder partners and may differ between Australia and New Zealand.**

The benefits conferred by this express warranty are in addition to the Consumer Guarantees referred to in section 3 and any other statutory rights you may have under the Australian / New Zealand Consumer Law and/or other applicable laws.

## 2. Warranty exclusions

This express warranty does not apply where:

- a) The product has been installed, used or operated otherwise than in accordance with the product manual or other similar documentation provided to you with the product;

---

# MANUFACTURER GUARANTEE

---

- b) The product requires repairs due to damage resulting from accident, misuse, incorrect installation, insect or vermin infestation, improper liquid spillage, cleaning or maintenance, unauthorised modification, use on an incorrect voltage, power surges and dips, voltage supply problems, tampering or unauthorised repairs by any persons, use of defective or incompatible accessories or exposure to abnormally corrosive conditions, events independent of human control which occurred after the goods left the control of Glen Dimplex;
- c) The repair relates to the replacement of consumable parts such as fuses and bulbs or any other parts of the product which require routine replacement;
- d) You are unable to provide us with reasonable proof of purchase for the product;
- e) the breakdown occurs after the expiry of the express warranty period set out in section 1 or
- f) the product was not purchased in Australia / New Zealand as a brand-new product.

### **3. Consumer guarantees**

Our goods come with guarantees that cannot be excluded under the Australian / New Zealand Consumer Law. You are entitled to a replacement or refund for a major failure and for compensation for any other reasonably foreseeable loss or damage. You are also entitled to have the goods repaired or replaced if the goods fail to be of acceptable quality and the failure does not amount to a major failure.

### **4. How to make a claim**

You may make a claim under this warranty through our website, contacting our customer care line or via email. Contact details for Glen Dimplex Australia and New Zealand can be found at the end of this document

To make a valid claim under this warranty, you must:

- a) Lodge the claim with us as soon as possible and no later than 14 days after you first become aware of the breakdown;
- b) Provide us with the product serial number;
- c) Provide us with reasonable proof of purchase for the product. This can take the form of a store receipt, new home handover form or other payment receipt documentation; and
- d) If required by us, provide us (or any person nominated by us) with access to the premises at which the product is located at times nominated by us (so that we can inspect the product).

---

## MANUFACTURER GUARANTEE

---

### 5. Warranty claims

If you make a valid claim under this warranty and none of the exclusions set out in section 2 apply, we will, at our election, either repair the product or replace the product with a product of identical specification (or where the product is superseded or no longer in stock, with a product of as close a specification as possible).

Goods presented for repair may be replaced by refurbished goods of the same type rather than being repaired. Refurbished parts may be used to repair the goods.

Products are designed and supplied for normal domestic use. We will not be liable to you under this warranty for business loss or damage of any kind whatsoever.



#### **Glen Dimplex Australia Pty Ltd**

[www.glendimplex.com.au](http://www.glendimplex.com.au)

#### **Australia**

Ph: 1300 556 816

[customer.care.ha@glendimplex.com.au](mailto:customer.care.ha@glendimplex.com.au)

#### **Glen Dimplex New Zealand Ltd**

[www.glendimplex.co.nz](http://www.glendimplex.co.nz)

#### **New Zealand**

Ph: 09 274 8265

[nztechserv@glendimplex.co.nz](mailto:nztechserv@glendimplex.co.nz)



---

**NOTES**

---



---

# MANUFACTURER GUARANTEE

---

## **READ THE INSTRUCTION BOOKLET BEFORE INSTALLING AND USING THE APPLIANCE.**

The manufacturer will not be responsible for any damage to property or to persons caused by incorrect installation or improper use of the appliance.

The manufacturer is not responsible for any inaccuracies, due to printing or transcription errors, contained in this manual. In addition, the appearance of the figures reported is also purely indicative.

The manufacturer reserves the right to make changes to its products when considered necessary and useful, without affecting the essential safety and operating characteristics.

Glen Dimplex constantly seeks ways to improve the specifications and designs of their products.

Whilst every effort is made to produce up to date literature, this document should not be regarded as an infallible guide. Actual product only should be used to derive cut out sizes.

All appliances must be installed by a qualified person/s with adherence to the relevant electrical, plumbing and building codes, with compliance being issued as required by state or national legislation.

Additionally, all upright cookers must have the anti-tilt device installed correctly in adherence to the relevant standards by a licenced installer. For maximum effectiveness and efficiency all rangehoods should be installed with the use of ductwork, by a licenced installer with adherence to the relevant state and national building codes and regulations.

All Glen Dimplex appliances are for Domestic use only, and must be installed by a licence installer into Domestic Applications only, without exception and to the required Authorities guidelines. Any installation outside of this will VOID warranty. Alfresco areas are not a Domestic application.

Distributed by:

### **Glen Dimplex Australia Pty Ltd**

For full terms and conditions, or to register your product warranty, please visit our website:

[www.glendimplex.com.au](http://www.glendimplex.com.au)

### **Glen Dimplex New Zealand Ltd**

[www.glendimplex.co.nz](http://www.glendimplex.co.nz)

For service advice, please contact the Customer Care Centre by phone or email below.

#### **Australia**

Ph: 1300 556 816

[customer.care.ha@glendimplex.com.au](mailto:customer.care.ha@glendimplex.com.au)

#### **New Zealand**

Ph: 09 274 8265

[nztechserv@glendimplex.co.nz](mailto:nztechserv@glendimplex.co.nz)